

6Cyl Split Seq High Imp Injector

Last Changed: 08/06/2021
 Harness Required: E33

A	B	C	D	E	F

Write your firing order from left to right in the blocks above marked with an alphabetical letter. Then write the corresponding number on the corresponding injector with the same alphabetical letter in the drawing below. Now connect your injector number to the corresponding colour wire.

Note: The order of the injectors will differ on their placing on the engine, as long as it is connected to the same colour wire as this illustration. Two injectors in three pairs will have the same colour wire because they are pulsed together. Connect them as such. Do the same procedure for straight six engines.

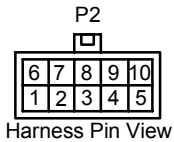
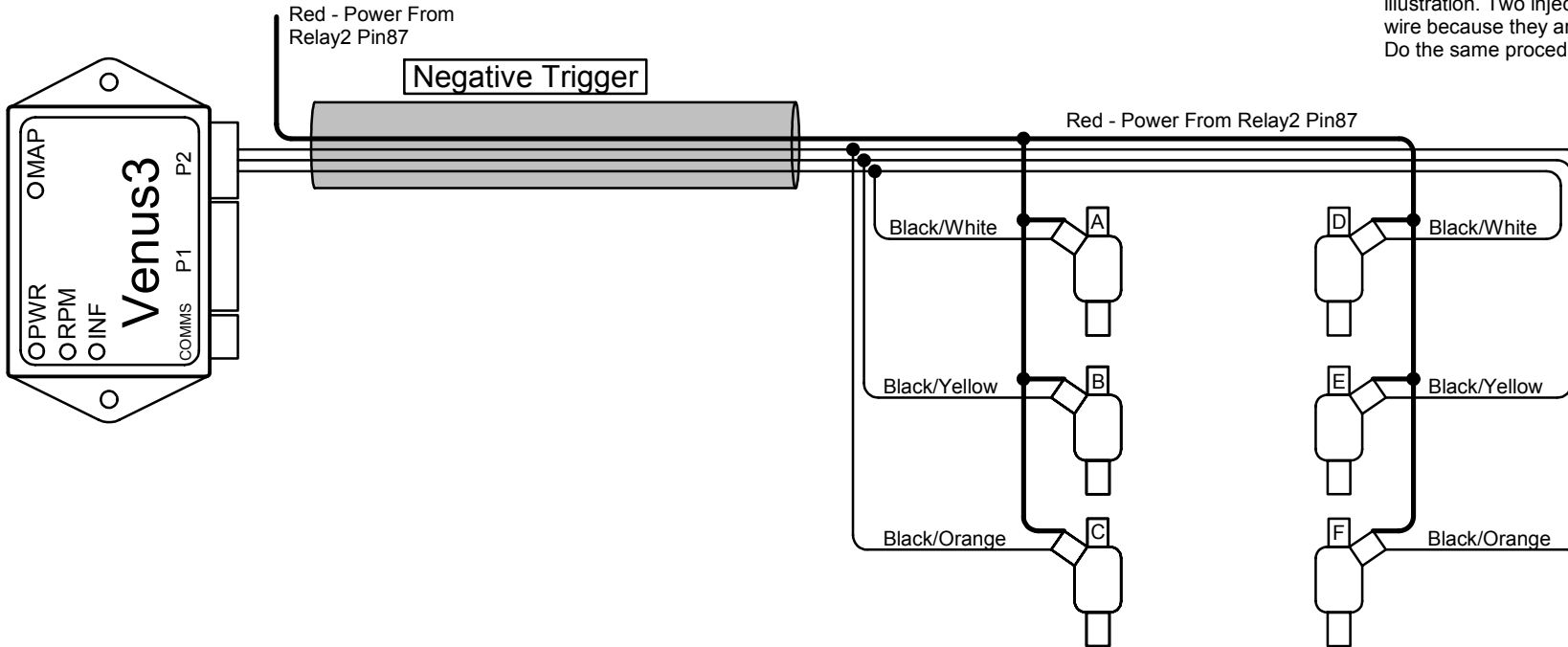

- Harness Pin View
- 1. Black/Purple -
 - 2. Black/Orange - Injector C & F
 - 3. Black/White - Injector A & D
 - 4. Blue -
 - 5. Blue/Orange -
 - 6. Black/Red -
 - 7. Black/Brown -
 - 8. Black/Yellow - Injector B & E
 - 9. Green -
 - 10. Blue/White -

Connector Pinouts

Software Settings

Injection Type ⚠

Split Seq 2x Inj Per Driver

Injector Driver Outputs

Injector Driver Output 1 **Coil Negative 6**

Injector Driver Output 2 **Coil Negative 5**

Injector Driver Output 3 **Coil Negative 4**