

ZF 4HP18 4Spd

Last Changed: 03/08/2019 Page: 1 of 2

Harness Required: OT01 - P1, OT03 - P2, E36 - P3, DB1 - Positive

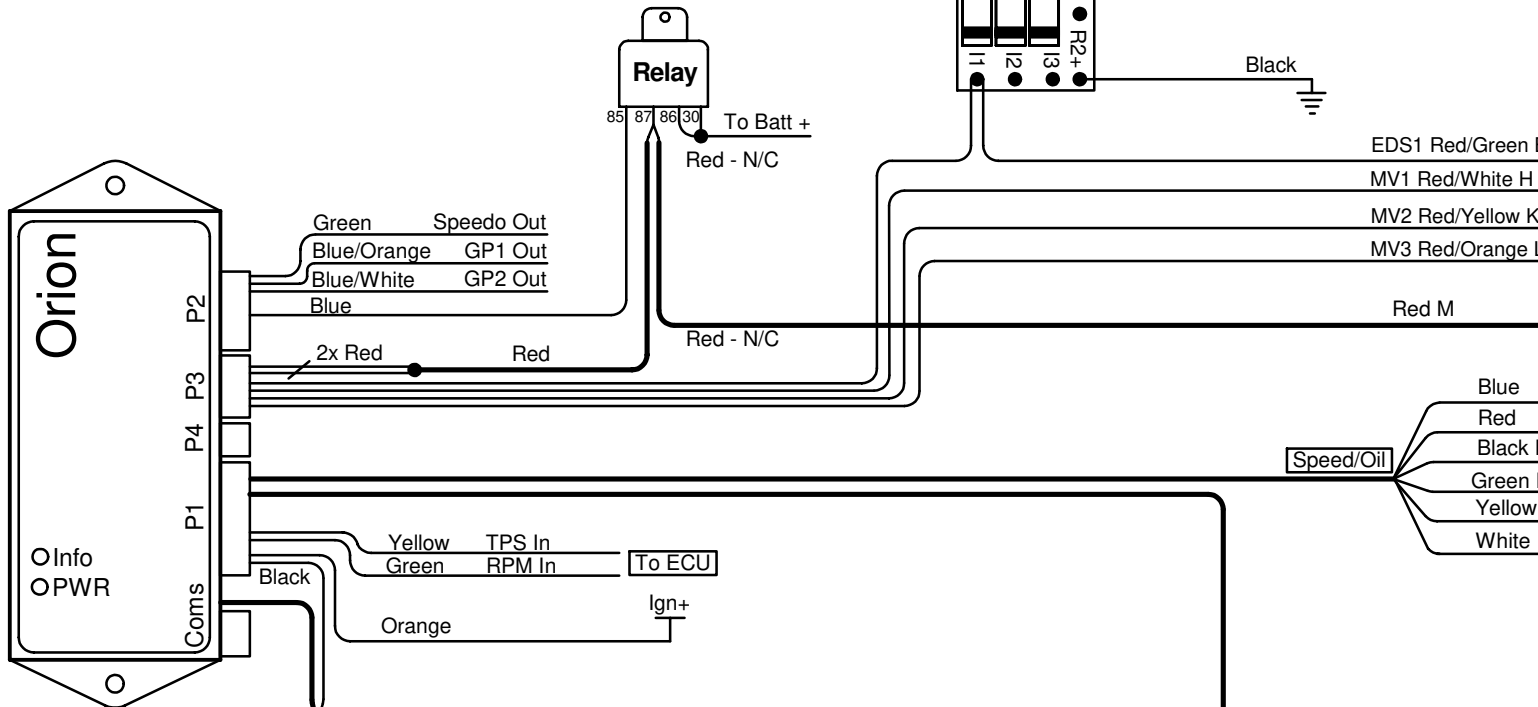

Gearbox Connector **NB! Looking into Case Conector**

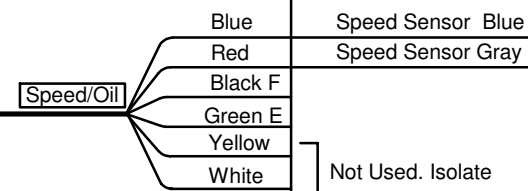
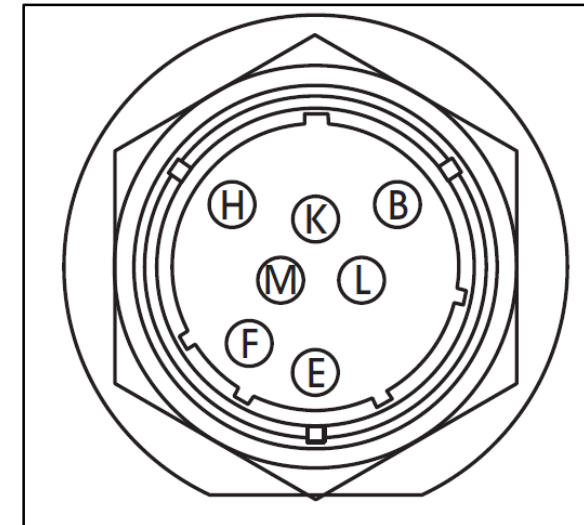

4HP24	Harness Color	Resistance
		Cold-Hot
H MV1	Gearbox Red/White	Shift 1 30 - 40 Ohm
K MV2	Gearbox Red/Yellow	Shift2 30 - 40 Ohm
L MV3	Gearbox Red/Orange	Shift3 30 - 40 Ohm
B EDS1	Gearbox Red/Green	Line Press 5 - 8 Ohm
E TFT	Speed/Oil Green	Temp Sensor 1K Ohm
F TFT	Speed/Oil Black	Temp Sensor
M PWR	Red	+12Volt to Solenoids

Scroll Down for more info

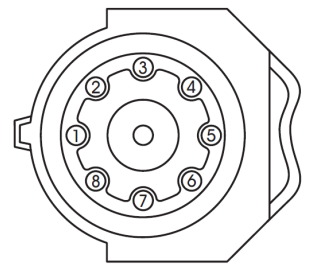
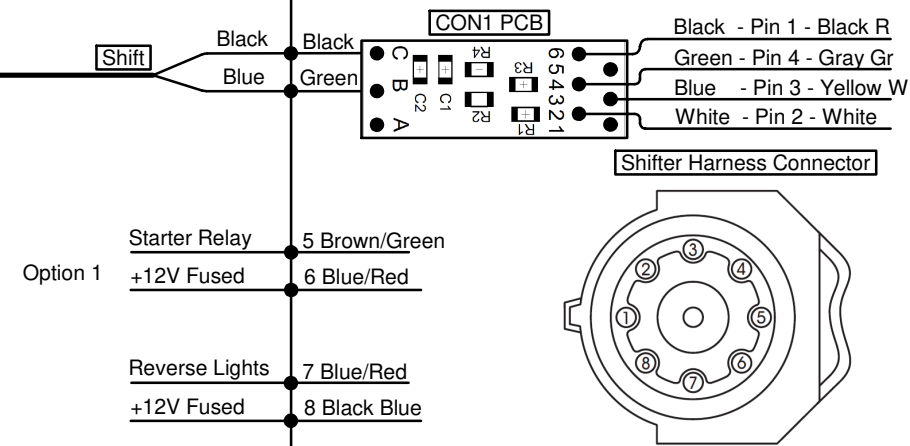
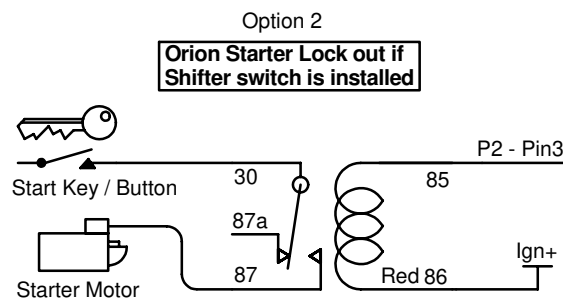

ZF 4HP18 4Spd

Last Changed: 03/08/2019 Page: 1 of 2

Harness Required: OT01 - P1, OT03 - P2, E36 - P3, DB1 - Positive

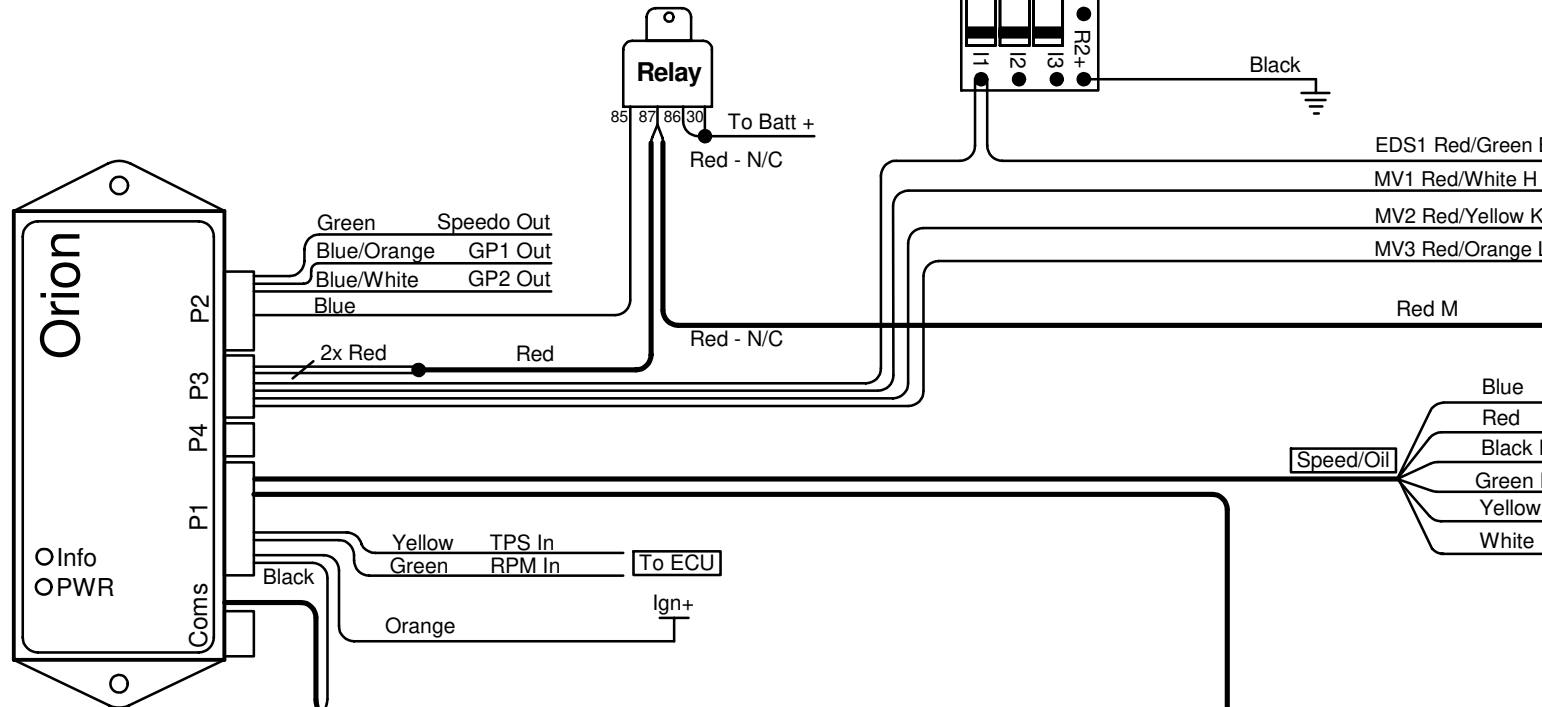

Gearbox Connector **NB! Looking into Case Conector**

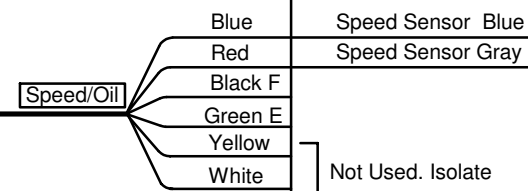
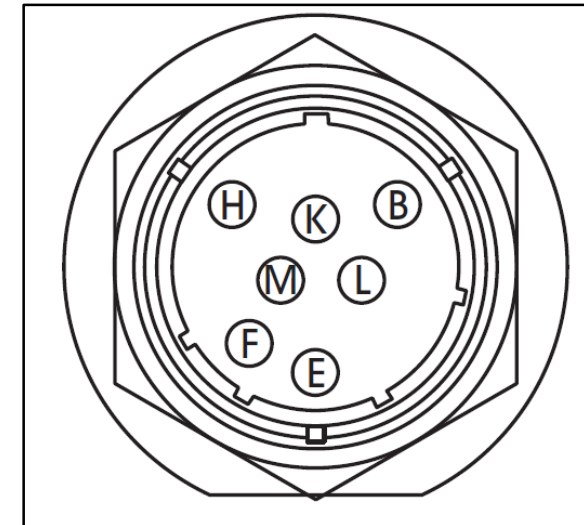

4HP24	Harness Color	Resistance
		Cold-Hot
H MV1	Gearbox Red/White	Shift 1 30 - 40 Ohm
K MV2	Gearbox Red/Yellow	Shift2 30 - 40 Ohm
L MV3	Gearbox Red/Orange	Shift3 30 - 40 Ohm
B EDS1	Gearbox Red/Green	Line Press 5 - 8 Ohm
E TFT	Speed/Oil Green	Temp Sensor 1K Ohm
F TFT	Speed/Oil Black	Temp Sensor
M PWR	Red	+12Volt to Solenoids

Scroll Down for more info

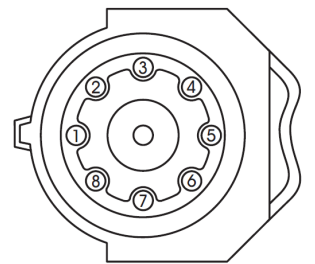
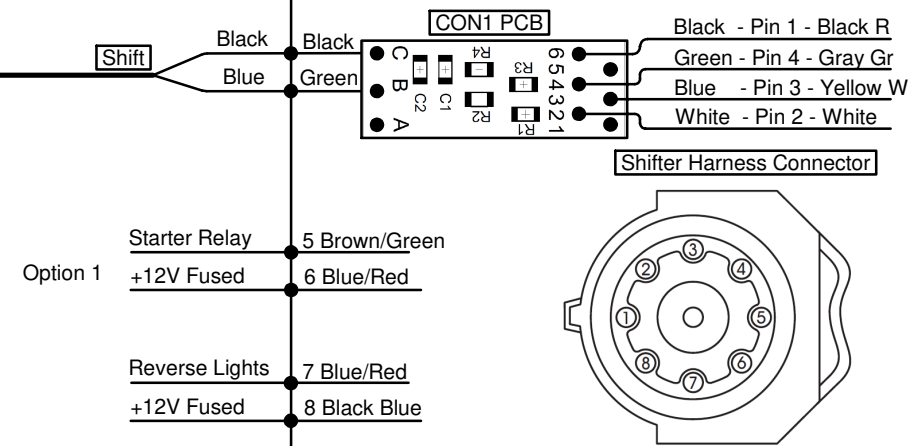
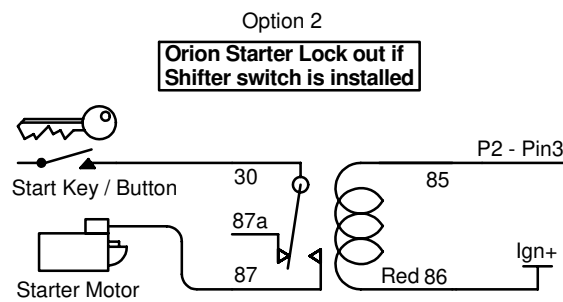

ZF 4HP18 4Spd

Last Changed: 03/08/2019 Page: 1 of 2

Harness Required: OT01 - P1, OT03 - P2, E36 - P3, DB1 - Positive

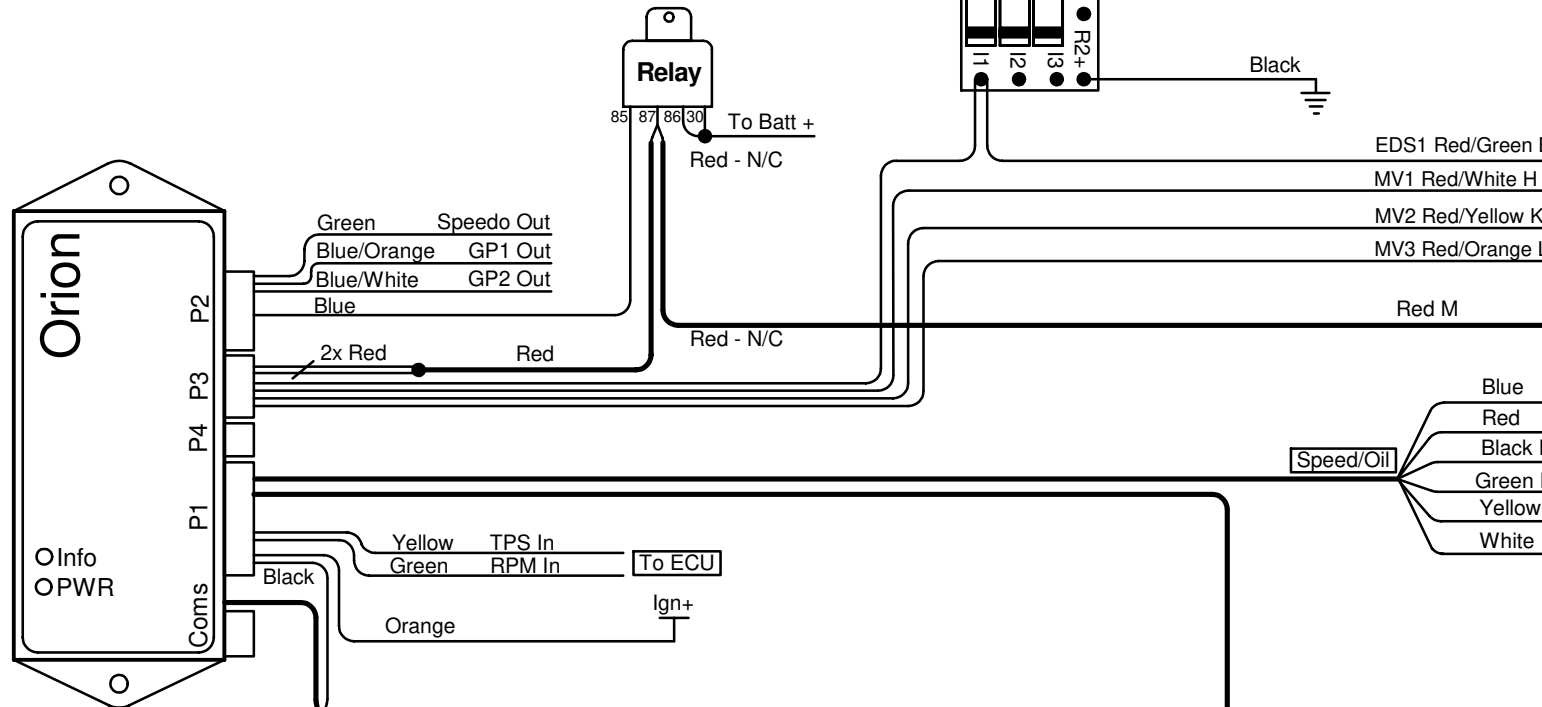

Gearbox Connector **NB! Looking into Case Conector**

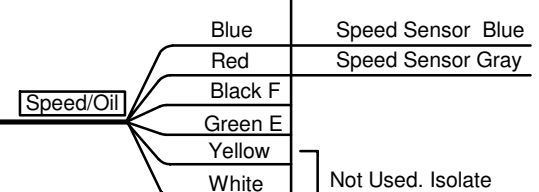
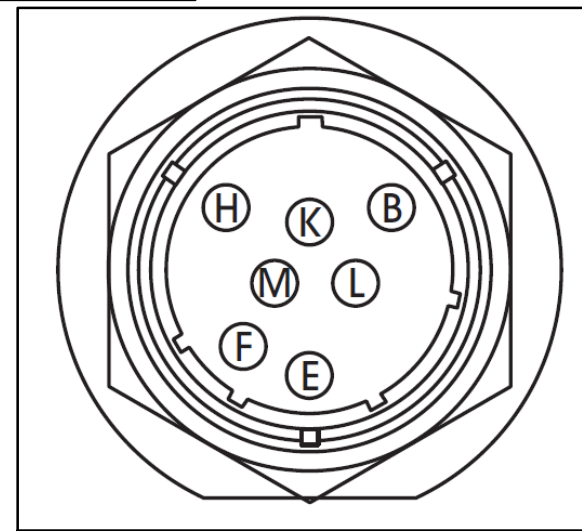

4HP24	Harness Color	Resistance
H MV1	Gearbox Red/White	Shift 1 30 - 40 Ohm
K MV2	Gearbox Red/Yellow	Shift2 30 - 40 Ohm
L MV3	Gearbox Red/Orange	Shift3 30 - 40 Ohm
B EDS1	Gearbox Red/Green	Line Press 5 - 8 Ohm
E TFT	Speed/Oil Green	Temp Sensor 1K Ohm
F TFT	Speed/Oil Black	Temp Sensor
M PWR	Red	+12Volt to Solenoids

Scroll Down for more info

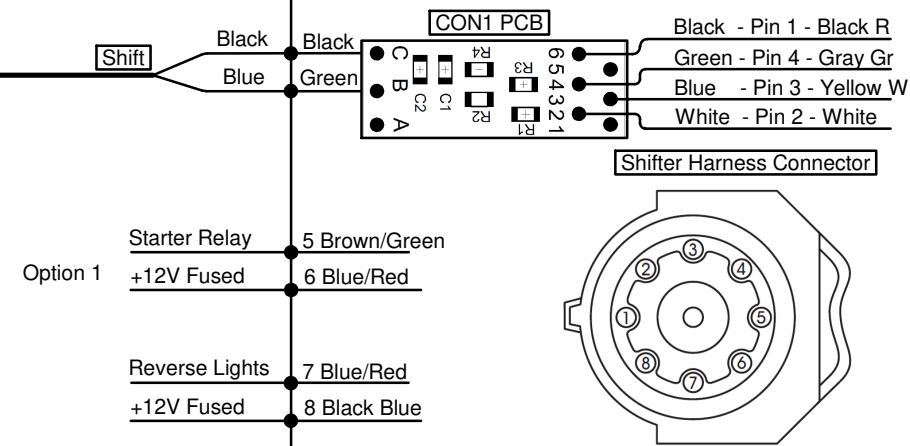
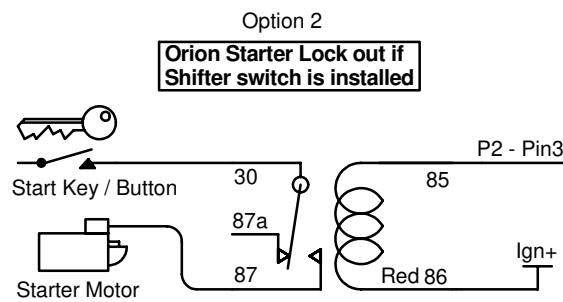

ZF 4HP18 4Spd

Last Changed: 03/08/2019 Page: 1 of 2

Harness Required: OT01 - P1, OT03 - P2, E36 - P3, DB1 - Positive

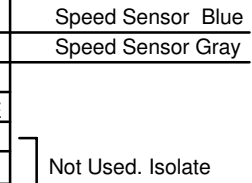
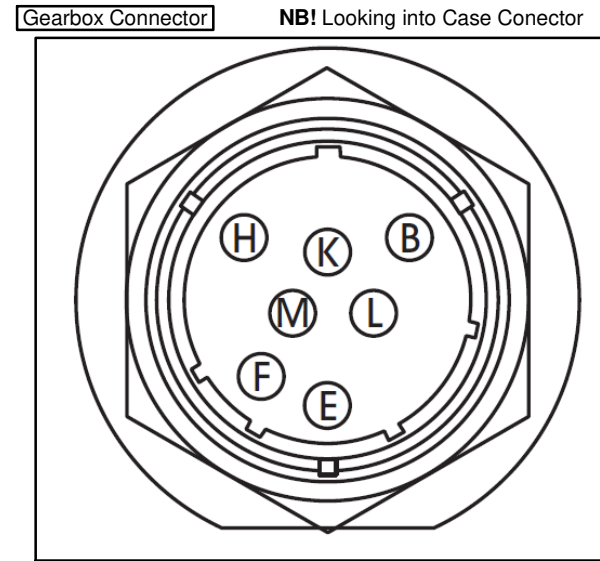
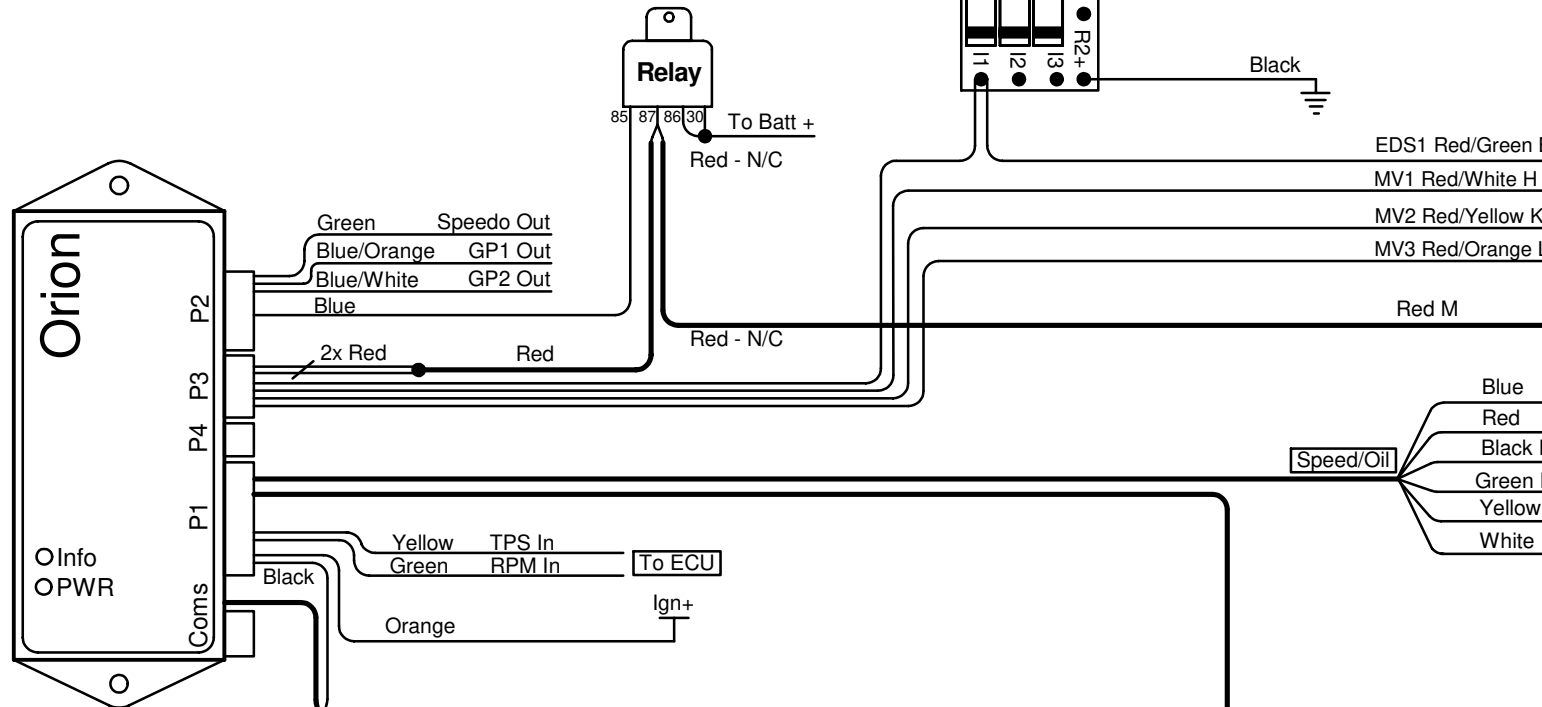

4HP24	Harness Color	Resistance
		Cold-Hot
H MV1	Gearbox Red/White	Shift 1 30 - 40 Ohm
K MV2	Gearbox Red/Yellow	Shift2 30 - 40 Ohm
L MV3	Gearbox Red/Orange	Shift3 30 - 40 Ohm
B EDS1	Gearbox Red/Green	Line Press 5 - 8 Ohm
E TFT	Speed/Oil Green	Temp Sensor 1K Ohm
F TFT	Speed/Oil Black	Temp Sensor
M PWR	Red	+12Volt to Solenoids

Scroll Down for more info

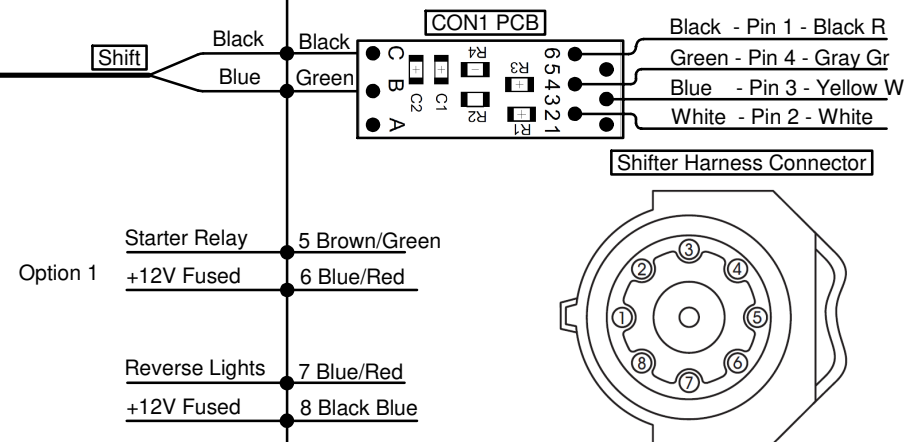
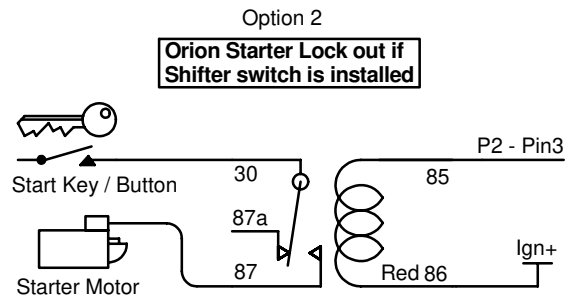

ZF 4HP18 4Spd

Last Changed: 03/08/2019 Page: 1 of 2

Harness Required: OT01 - P1, OT03 - P2, E36 - P3, DB1 - Positive

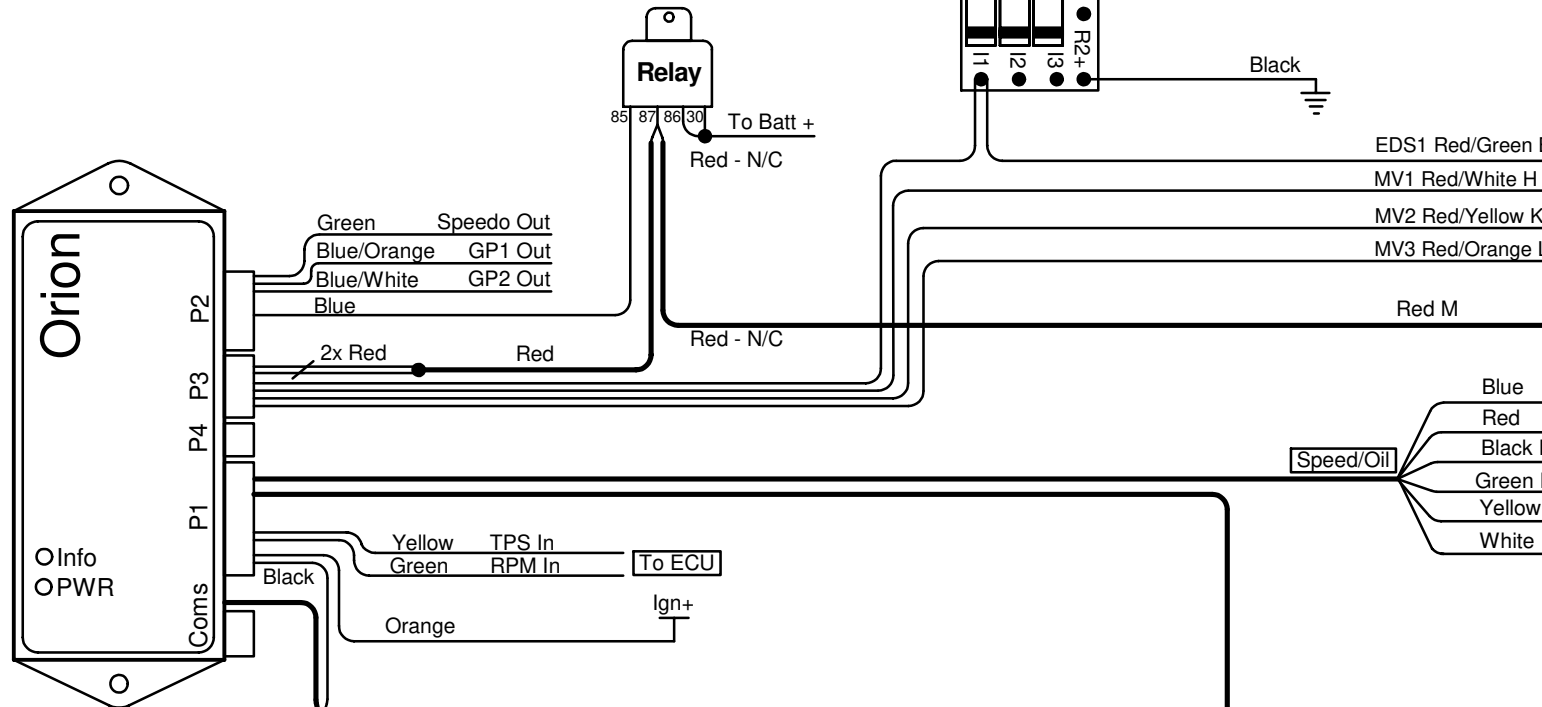

Gearbox Connector **NB! Looking into Case Conector**

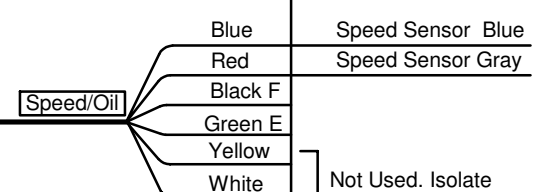
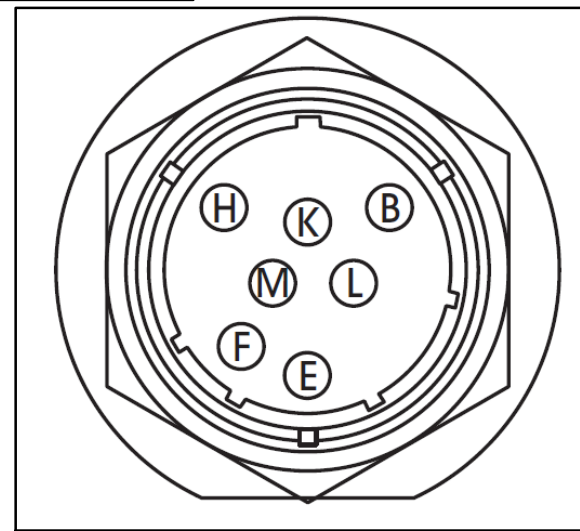

4HP24	Harness Color	Resistance
		Cold-Hot
H MV1	Gearbox Red/White	Shift 1 30 - 40 Ohm
K MV2	Gearbox Red/Yellow	Shift2 30 - 40 Ohm
L MV3	Gearbox Red/Orange	Shift3 30 - 40 Ohm
B EDS1	Gearbox Red/Green	Line Press 5 - 8 Ohm
E TFT	Speed/Oil Green	Temp Sensor 1K Ohm
F TFT	Speed/Oil Black	Temp Sensor
M PWR	Red	+12Volt to Solenoids

Scroll Down for more info

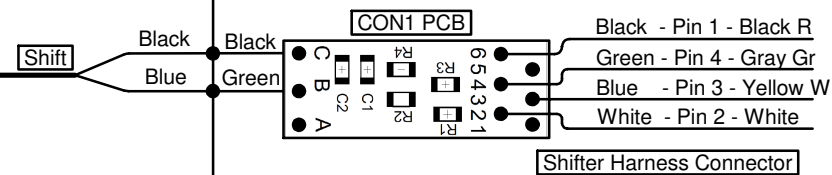
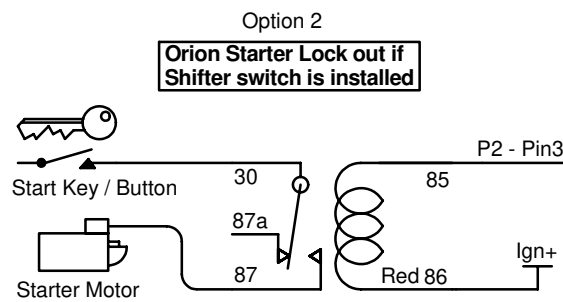

Shifter Harness Connector

- Option 1
- Starter Relay 5 Brown/Green
- +12V Fused 6 Blue/Red
- Reverse Lights 7 Blue/Red
- +12V Fused 8 Black Blue

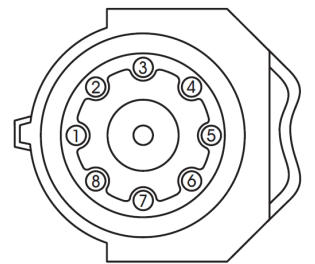

ZF 4HP18 4Spd

Last Changed: 03/08/2019 Page: 2 of 2

Harness Required: OT01 - P1, OT03 - P2, E36 - P3, DB1 - Positive

Ign+
|
T Ignition Power
|
Earth
**Terminal Connections
with the same name
are tied together**

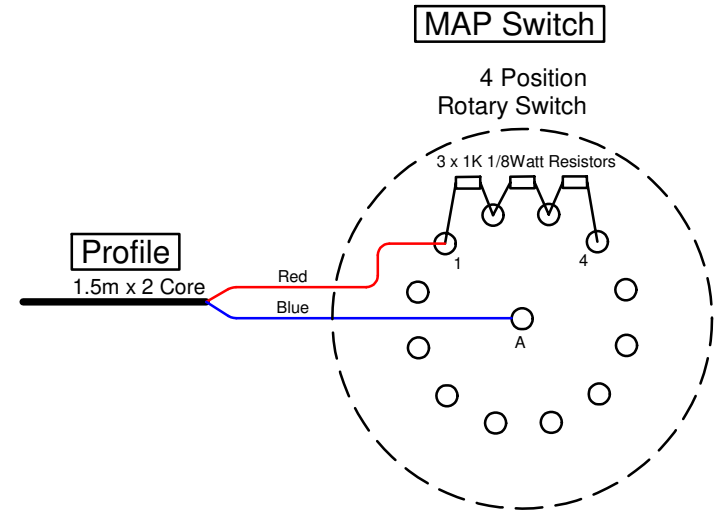
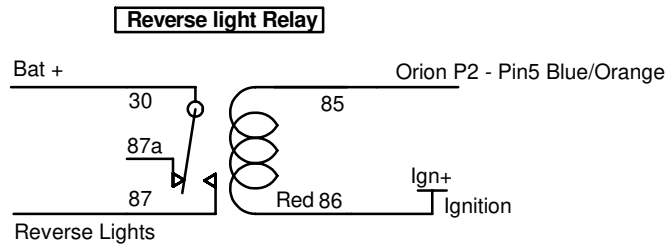
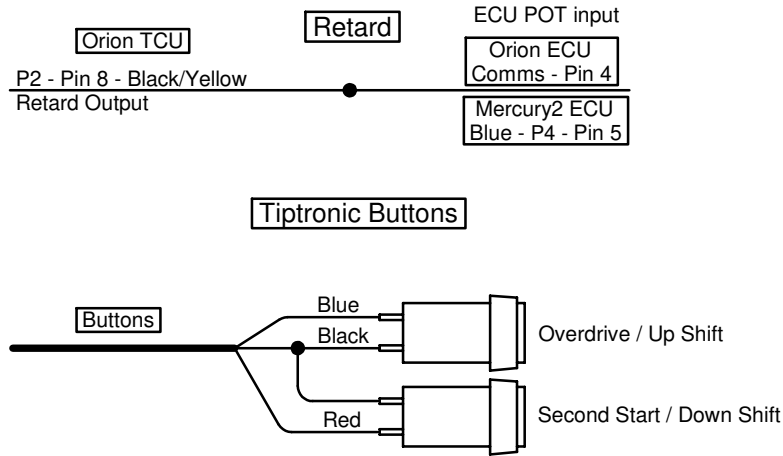

Note: Harnesses pin-outs and colours are layed out on the GP Priority Sheet

ZF 4HP18 4Spd

Last Changed: 03/08/2019 Page: 2 of 2

Harness Required: OT01 - P1, OT03 - P2, E36 - P3, DB1 - Positive

Ign+
|
T Ignition Power
|
Earth
**Terminal Connections
with the same name
are tied together**

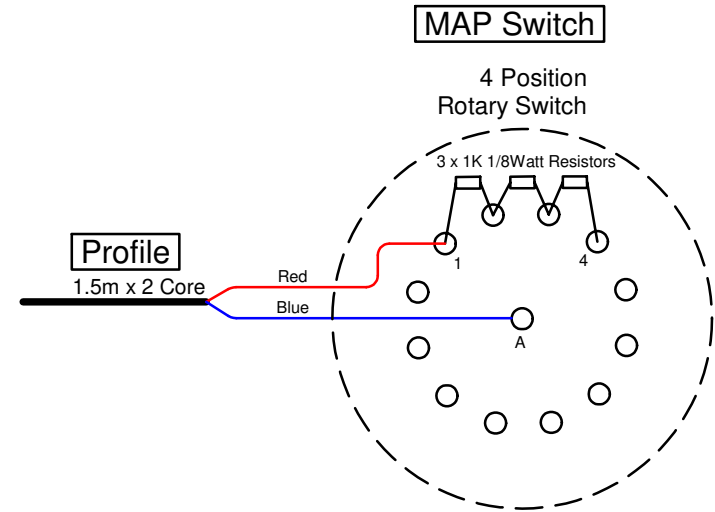
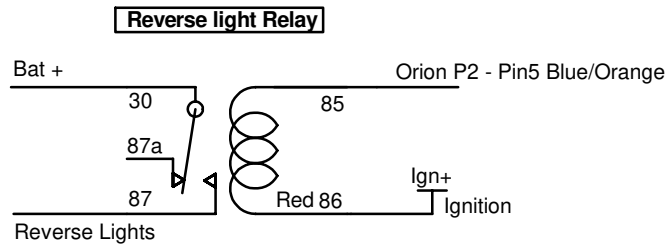
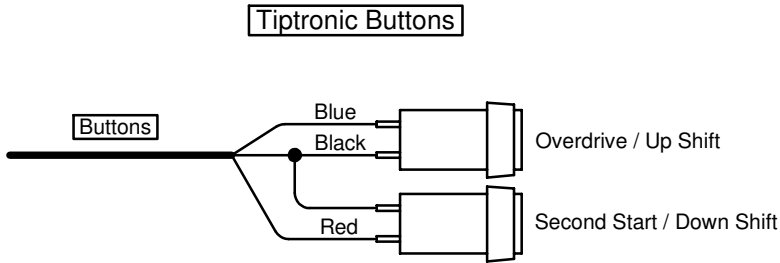
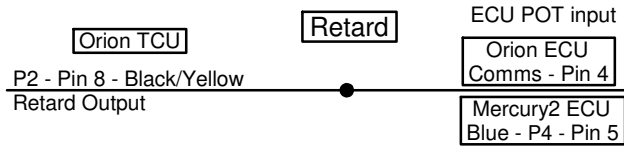

Note: Harnesses pin-outs and colours are layed out on the GP Priority Sheet

ZF 4HP18 4Spd

Last Changed: 03/08/2019 Page: 2 of 2

Harness Required: OT01 - P1, OT03 - P2, E36 - P3, DB1 - Positive

Ign+
|
T Ignition Power
|
Earth
**Terminal Connections
with the same name
are tied together**

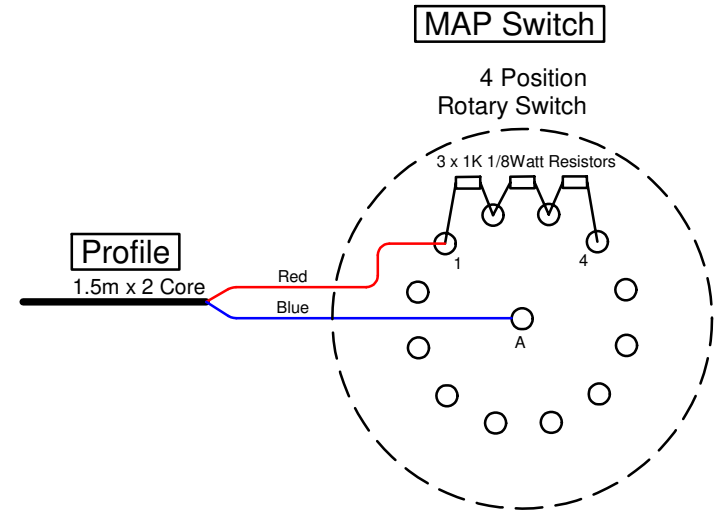
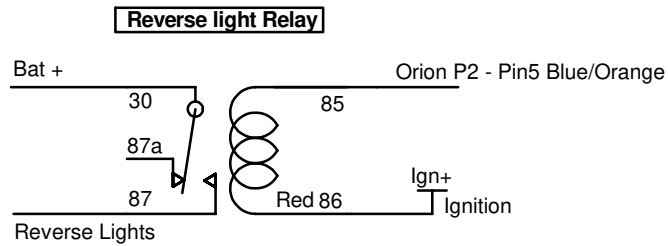
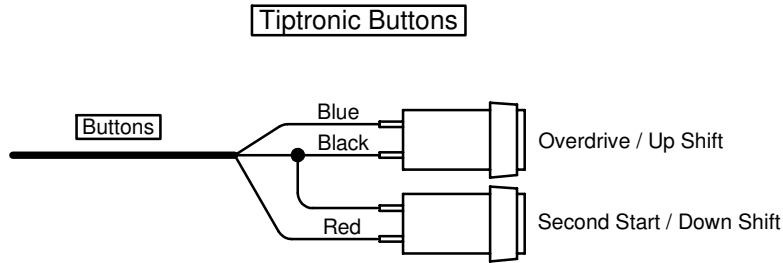
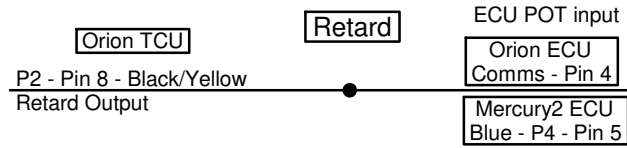

Note: Harnesses pin-outs and colours are layed out on the GP Priority Sheet

ZF 4HP18 4Spd

Last Changed: 03/08/2019 Page: 2 of 2

Harness Required: OT01 - P1, OT03 - P2, E36 - P3, DB1 - Positive

Ign+
|
T Ignition Power
|
Earth
**Terminal Connections
with the same name
are tied together**

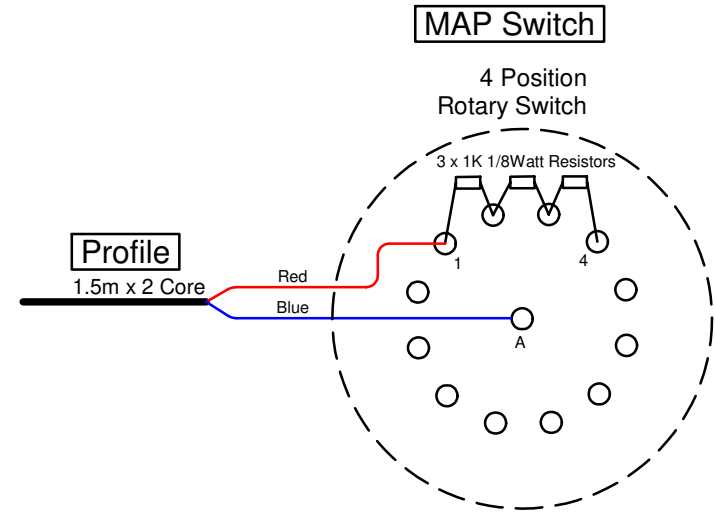
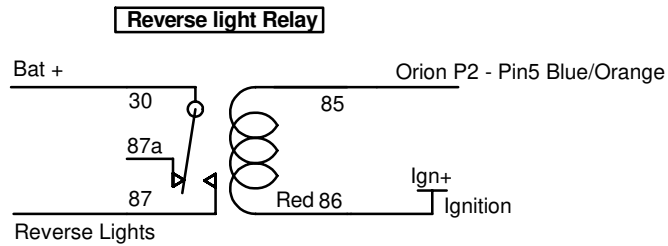
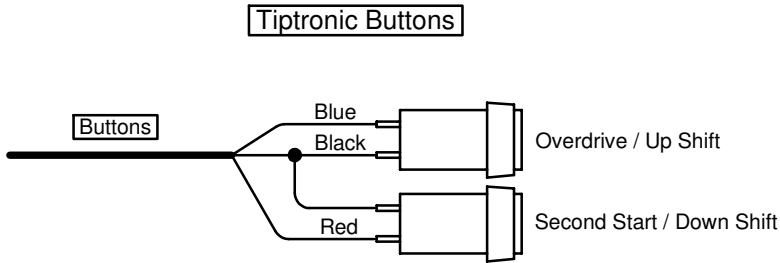
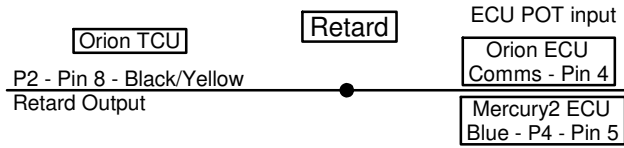

Note: Harnesses pin-outs and colours are layed out on the GP Priority Sheet

ZF 4HP18 4Spd

Last Changed: 03/08/2019 Page: 2 of 2

Harness Required: OT01 - P1, OT03 - P2, E36 - P3, DB1 - Positive

Ign+
|
T Ignition Power
|
Earth
**Terminal Connections
with the same name
are tied together**

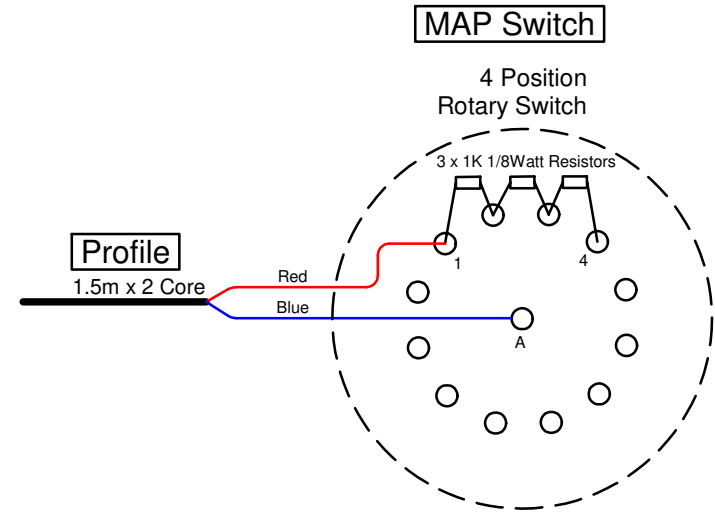
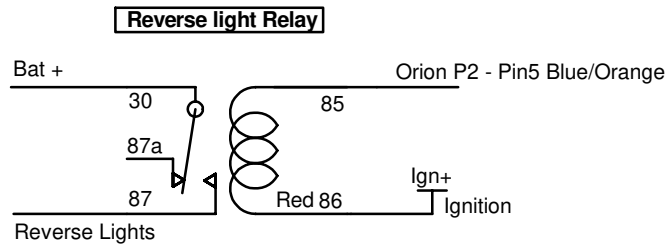
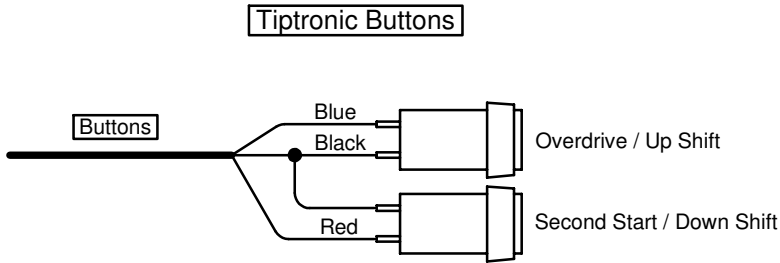
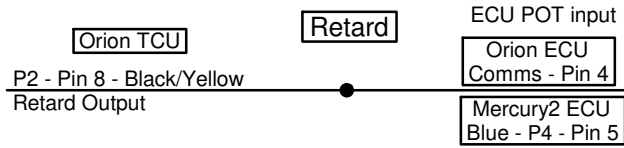

Note: Harnesses pin-outs and colours are layed out on the GP Priority Sheet