

Aisin A343E 4Speed St

Last Changed: 30/10/2019 Page 1 of 2
 Harness Required: MTWX02-2, DB1 Positive, CON2

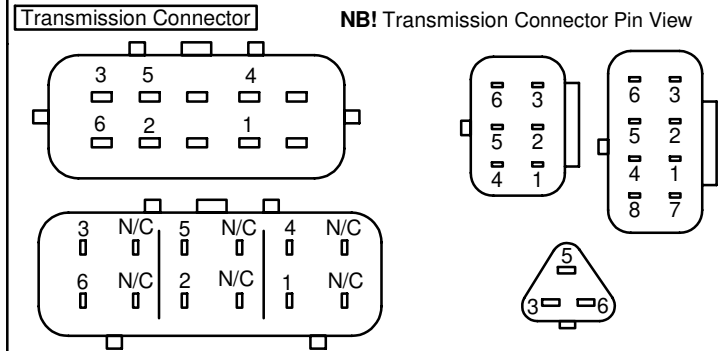

Pin	Harness	Color	Connector	Resistance	
				Cold	Hot
1	Earth	Black			
2	Earth	Black			
3	Gearbox	Red/White	S1	P2-1	11 18 Ω
4	Gearbox	Red/Blue	SLT	P2-5	3.5 4.6 Ω
5	Gearbox	Red/Black	SLU	P2-8	3.5 4.6 Ω
6	Gearbox	Red/Yellow	S2	P2-6	11 18 Ω
7	N/C				
8	N/C				

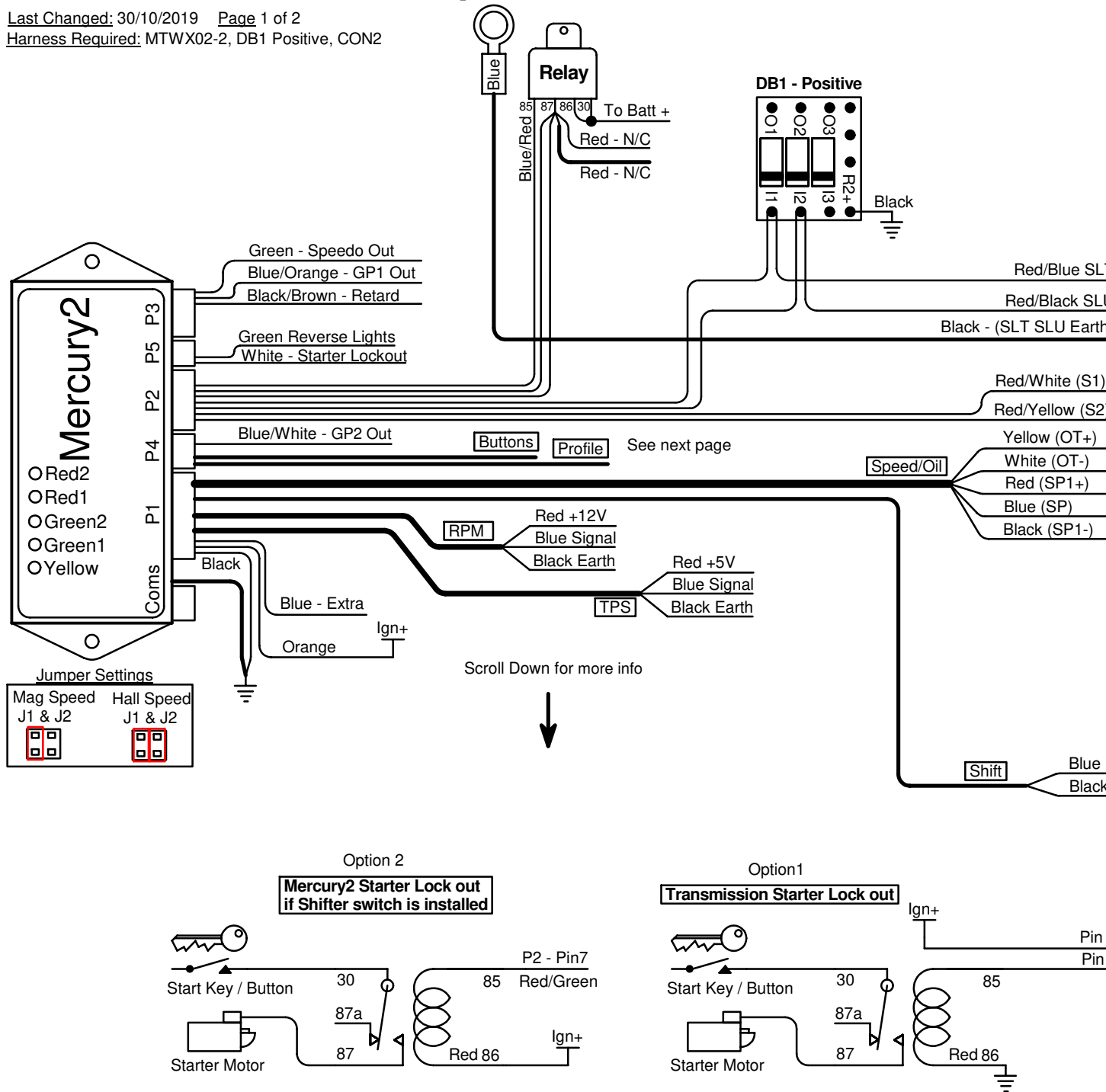
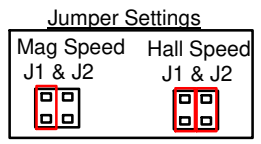
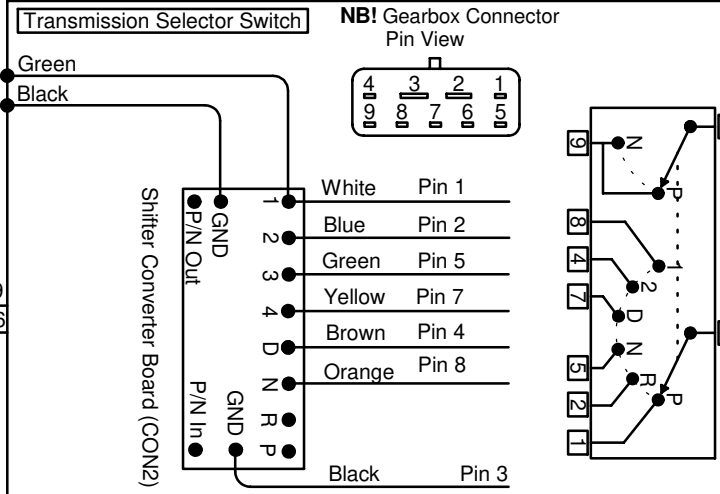
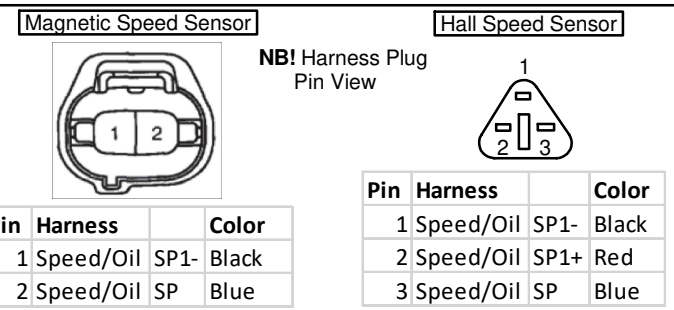

Scroll Down for more info

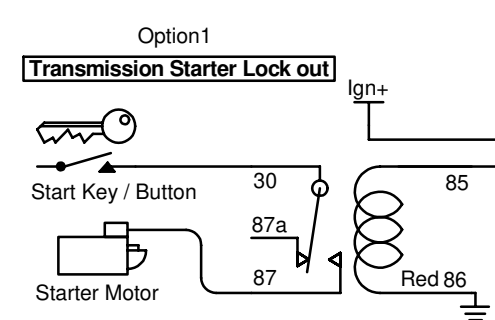
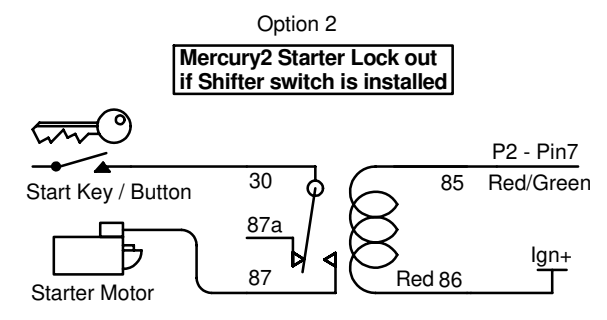

Aisin A343E 4Speed St

Last Changed: 30/10/2019 Page 1 of 2
 Harness Required: MTWX02-2, DB1 Positive, CON2

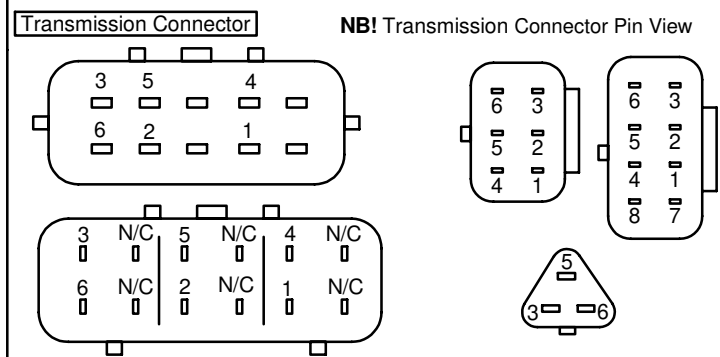
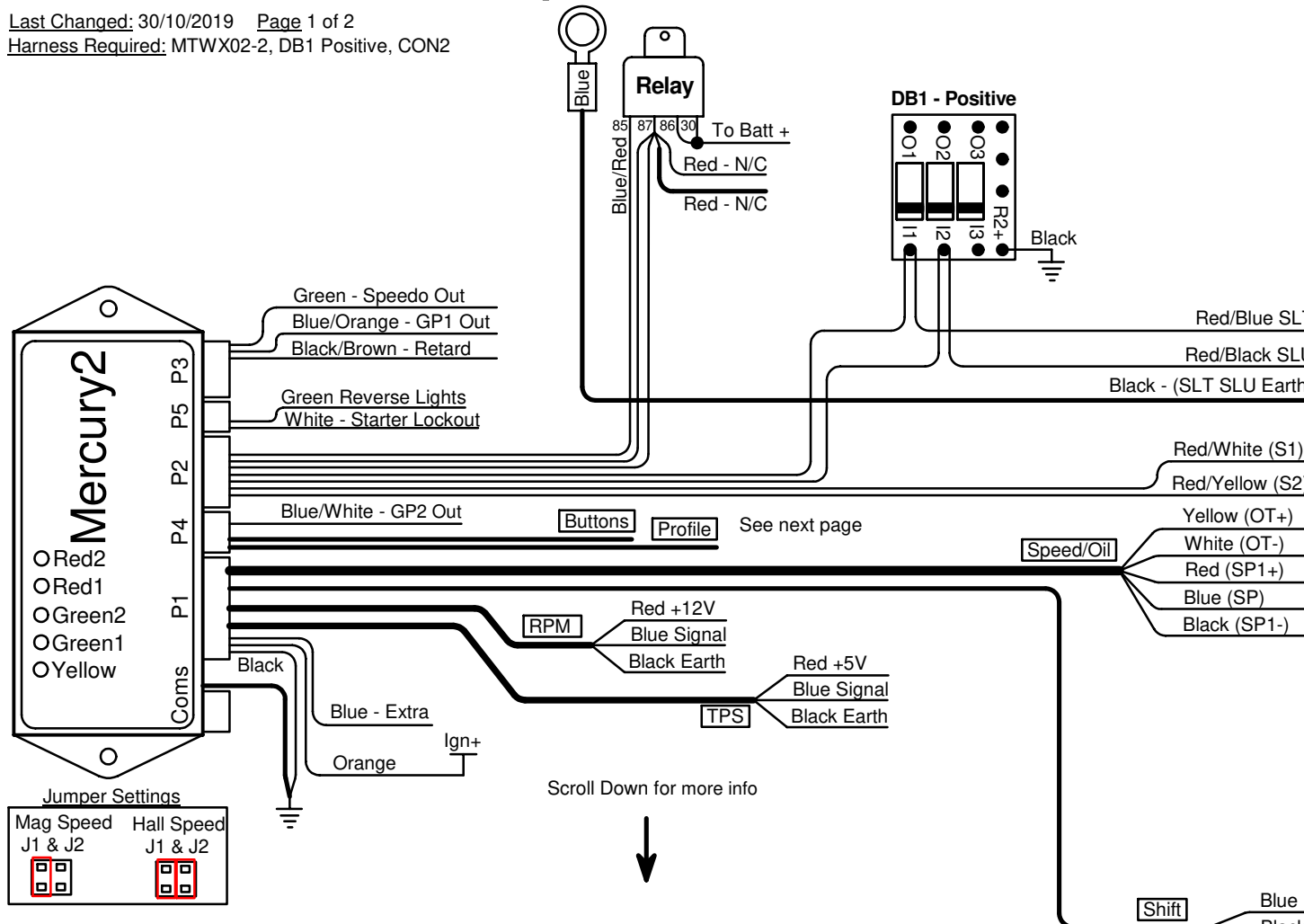

Pin	Harness	Color	Connector	Resistance	
				Cold	Hot
1	Earth	Black			
2	Earth	Black			
3	Gearbox	Red/White	S1	P2-1	11 18 Ω
4	Gearbox	Red/Blue	SLT	P2-5	3.5 4.6 Ω
5	Gearbox	Red/Black	SLU	P2-8	3.5 4.6 Ω
6	Gearbox	Red/Yellow	S2	P2-6	11 18 Ω
7	N/C				
8	N/C				

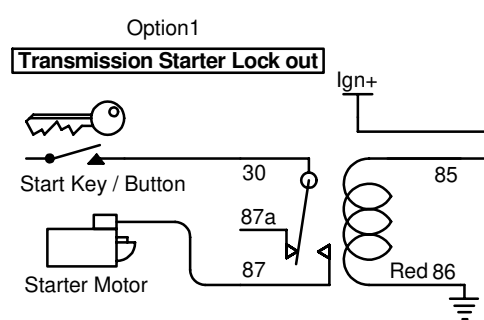
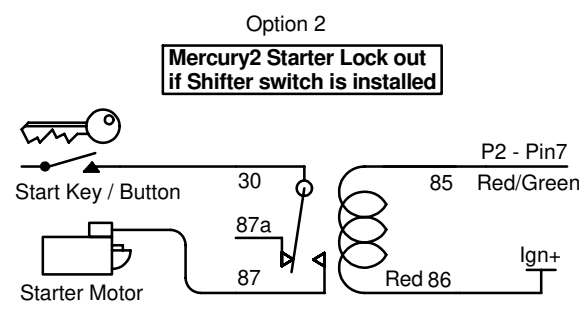
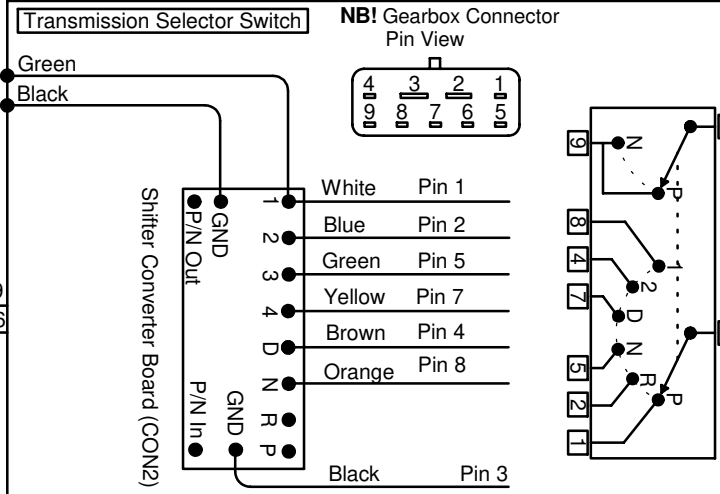
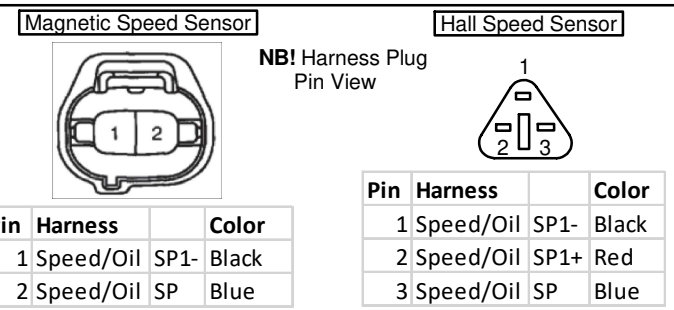

Aisin A343E 4Speed St

Last Changed: 30/10/2019 Page 1 of 2
 Harness Required: MTWX02-2, DB1 Positive, CON2

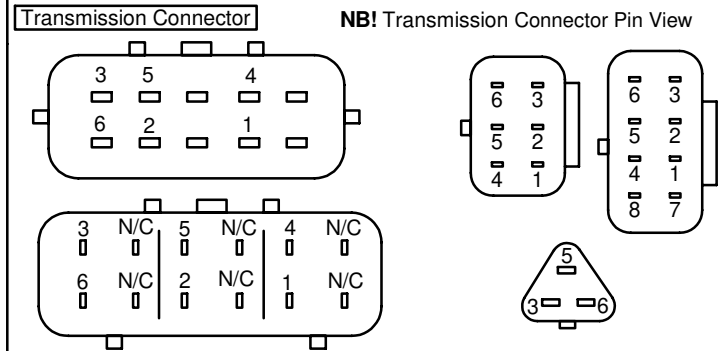
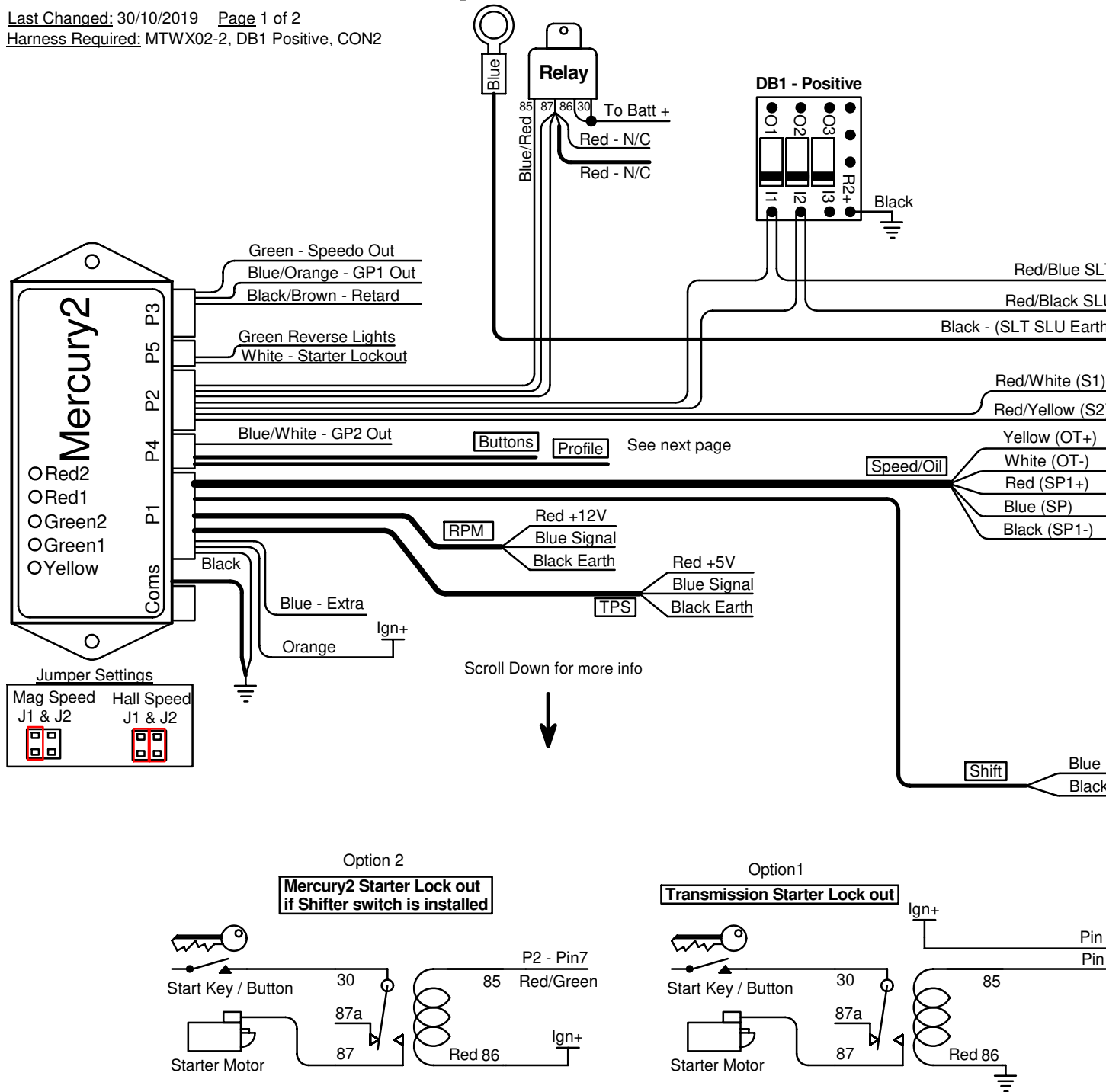

Pin	Harness	Color	Connector	Resistance	
				Cold	Hot
1	Earth	Black			
2	Earth	Black			
3	Gearbox	Red/White	S1	P2-1	11 18 Ω
4	Gearbox	Red/Blue	SLT	P2-5	3.5 4.6 Ω
5	Gearbox	Red/Black	SLU	P2-8	3.5 4.6 Ω
6	Gearbox	Red/Yellow	S2	P2-6	11 18 Ω
7	N/C				
8	N/C				

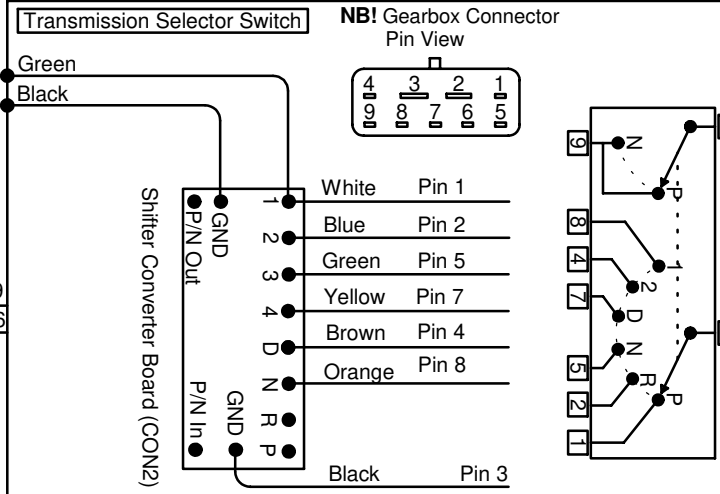
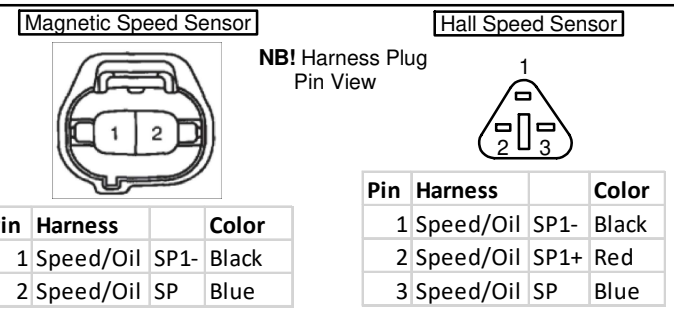

Aisin A343E 4Speed St

Last Changed: 30/10/2019 Page 1 of 2
 Harness Required: MTWX02-2, DB1 Positive, CON2

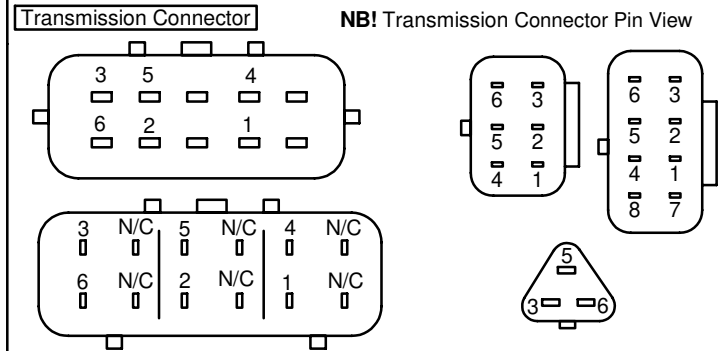
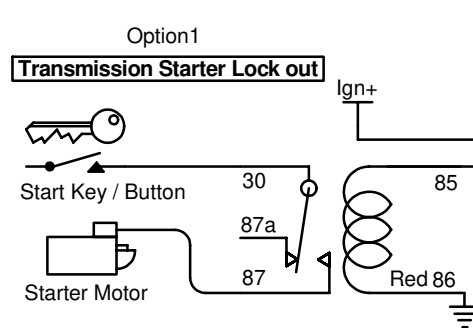
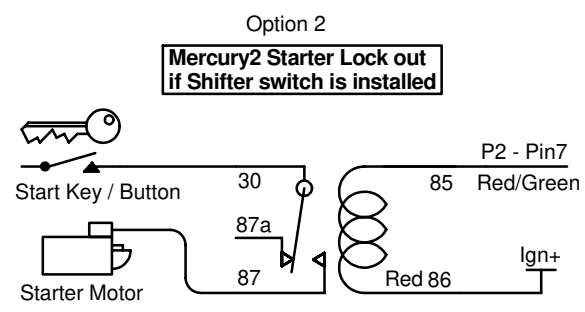
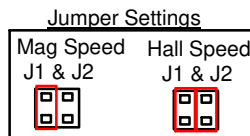
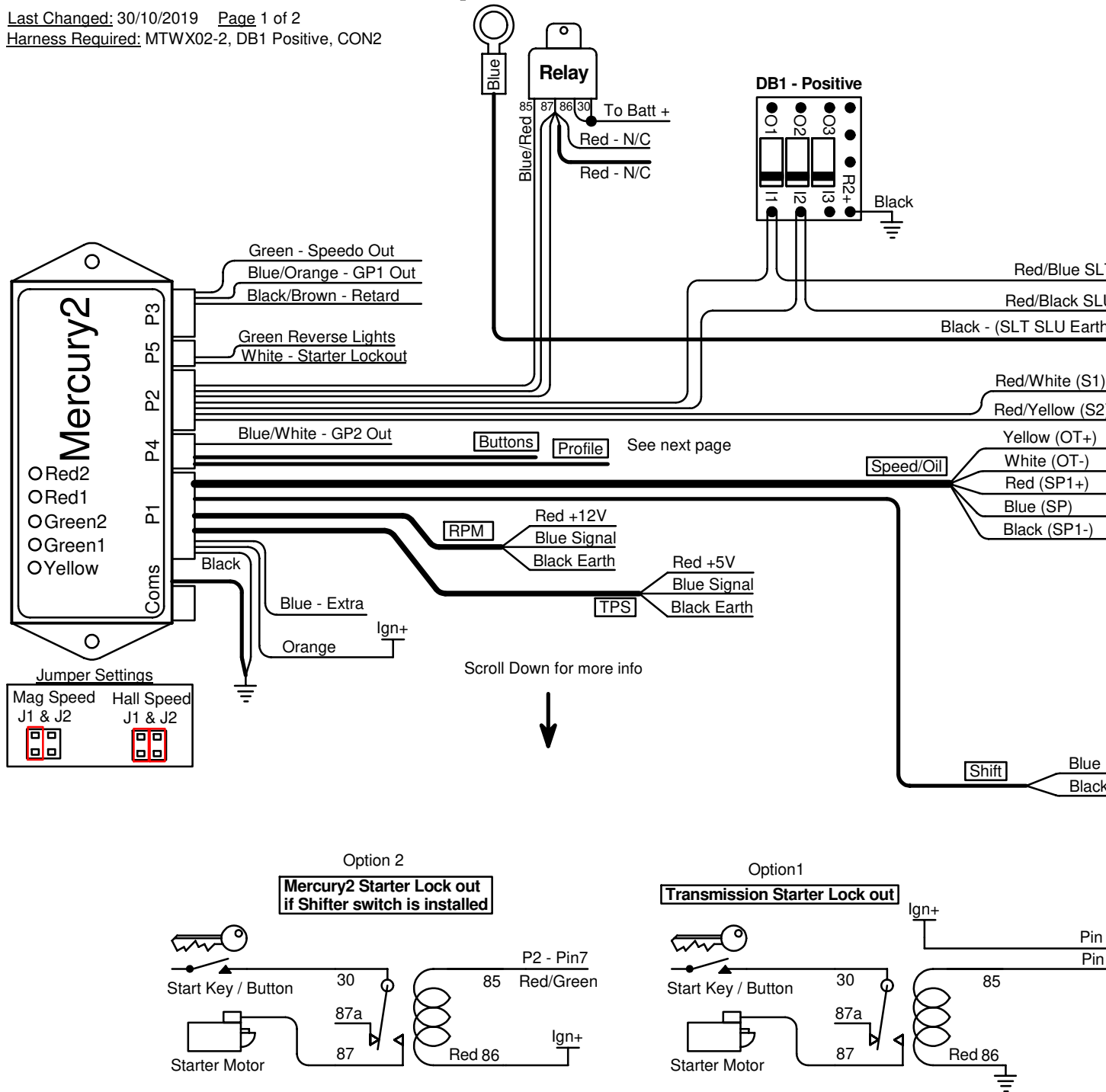

Pin	Harness	Color	Connector	Resistance	
				Cold	Hot
1	Earth	Black			
2	Earth	Black			
3	Gearbox	Red/White	S1	P2-1	11 18 Ω
4	Gearbox	Red/Blue	SLT	P2-5	3.5 4.6 Ω
5	Gearbox	Red/Black	SLU	P2-8	3.5 4.6 Ω
6	Gearbox	Red/Yellow	S2	P2-6	11 18 Ω
7	N/C				
8	N/C				

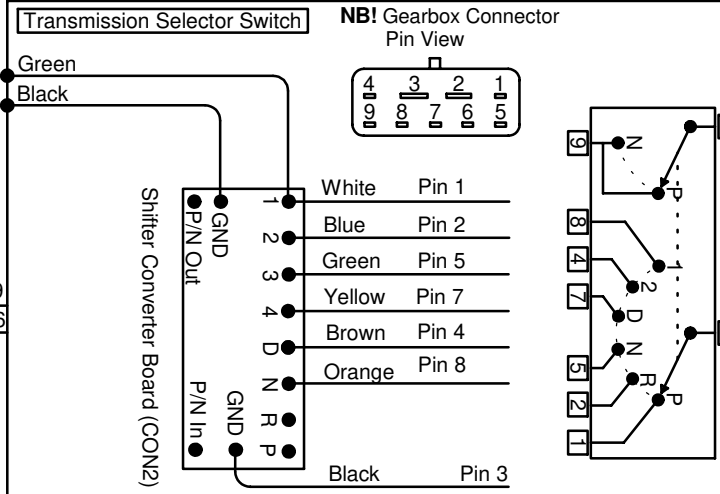
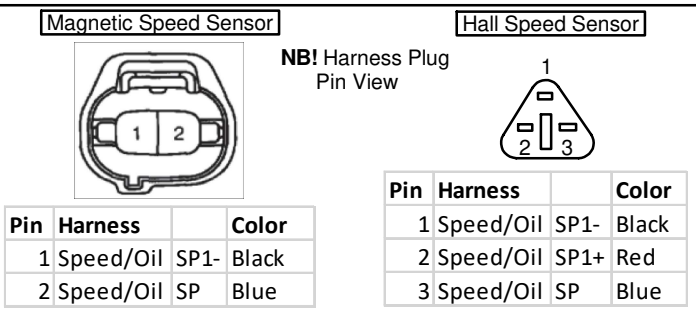

Aisin A343E 4Speed St

Last Changed: 30/10/2019 Page 1 of 2
 Harness Required: MTWX02-2, DB1 Positive, CON2

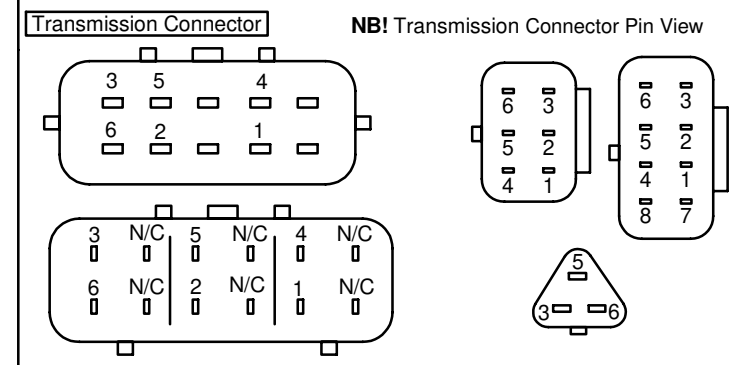
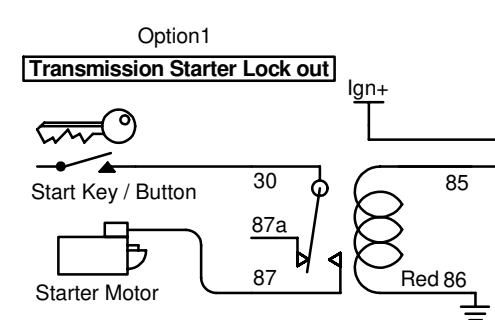
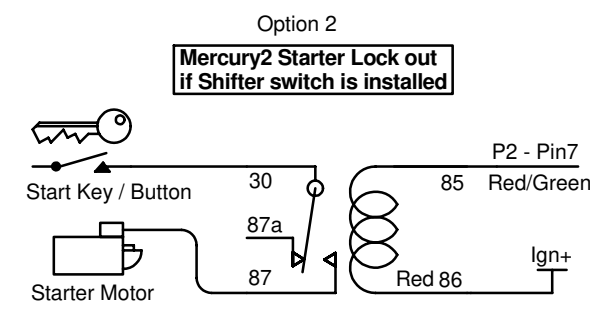
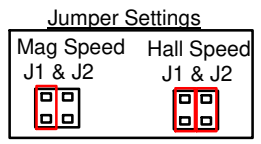
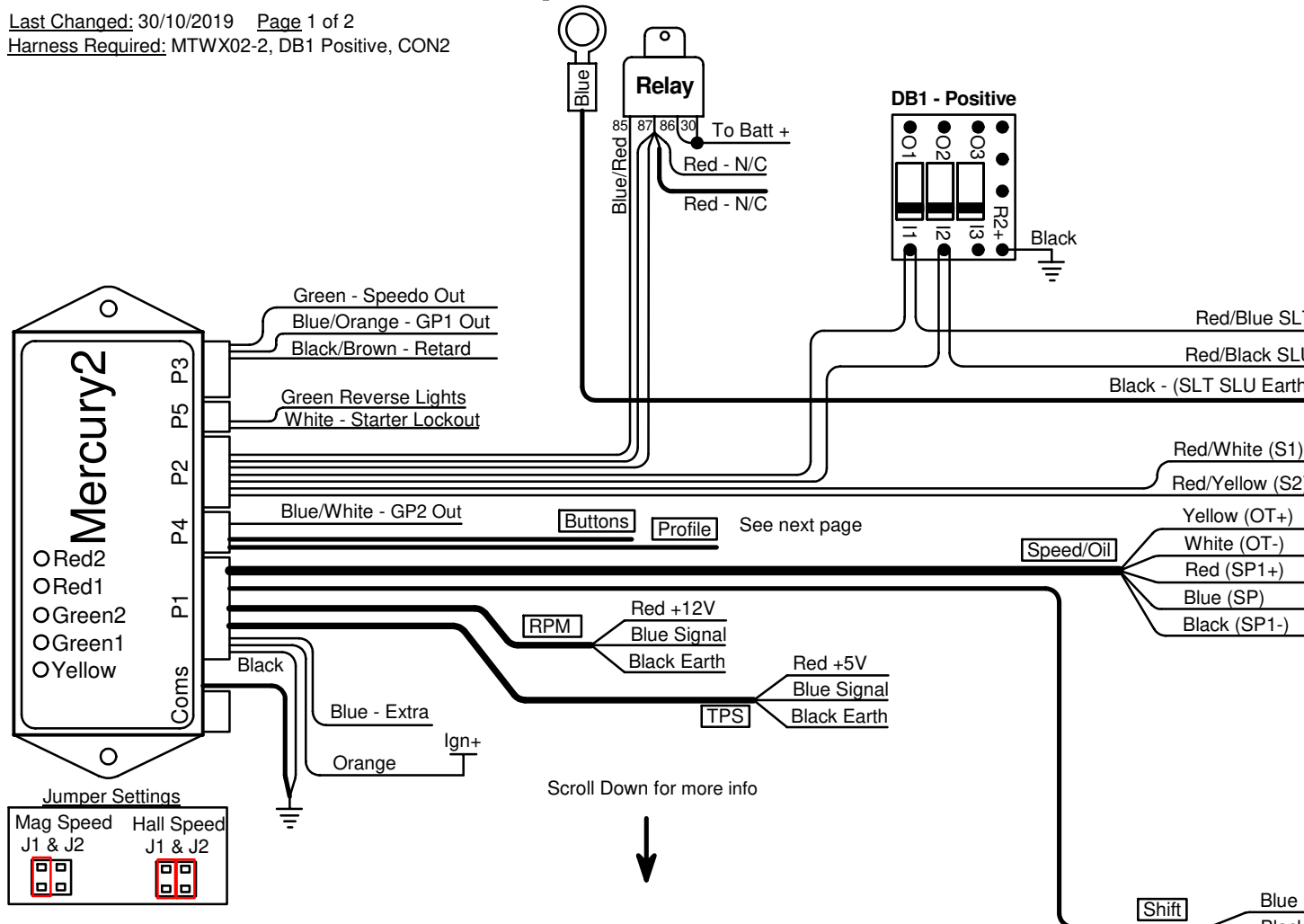

Pin	Harness	Color	Connector	Resistance	
				Cold	Hot
1	Earth	Black			
2	Earth	Black			
3	Gearbox	Red/White	S1	P2-1	11 18 Ω
4	Gearbox	Red/Blue	SLT	P2-5	3.5 4.6 Ω
5	Gearbox	Red/Black	SLU	P2-8	3.5 4.6 Ω
6	Gearbox	Red/Yellow	S2	P2-6	11 18 Ω
7	N/C				
8	N/C				

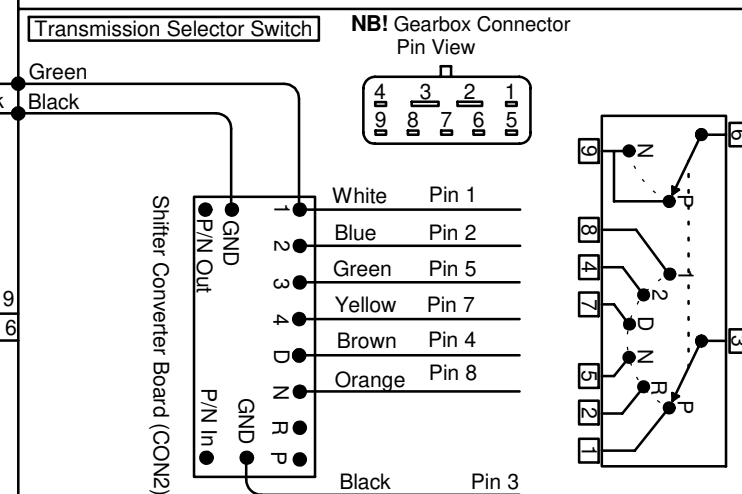
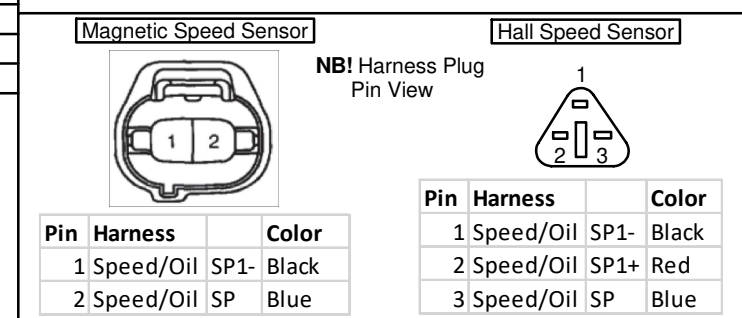

Aisin A343E 4Speed

Last Changed: 21/08/2019 Page 2 of 2

Harness Required: MTWX02/2, CON2, DB1 Positive

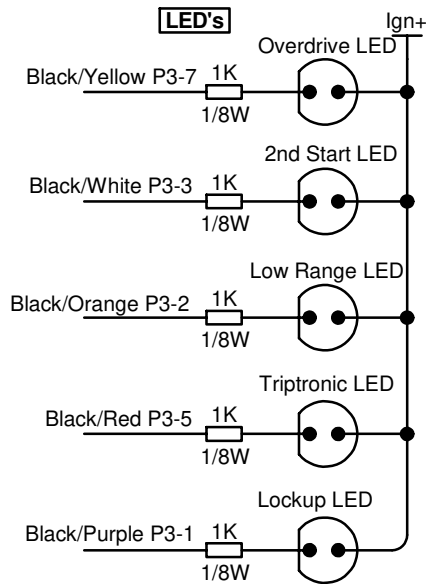

NB! Resistors are required LED's

Timing Retard Circuit

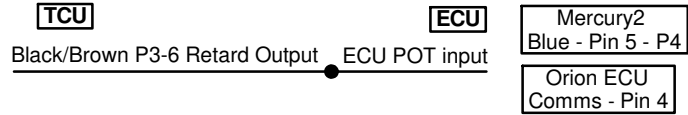

Tiptronic Buttons

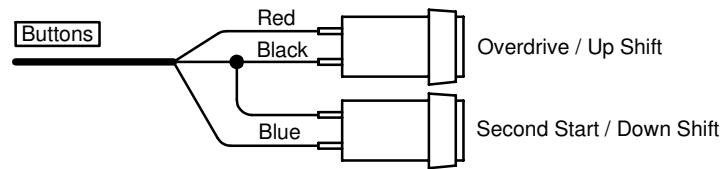

Reverse light Relay

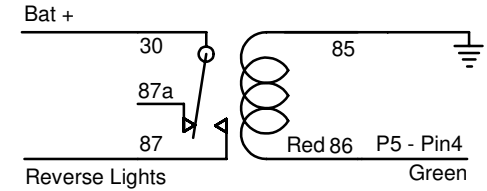

4 Map Switch

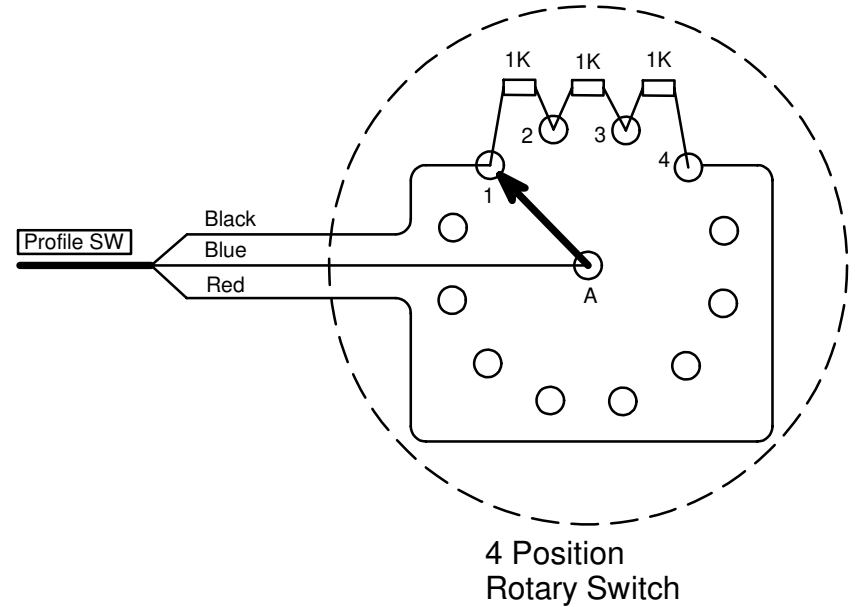

Aisin A343E 4Speed

Last Changed: 21/08/2019 Page 2 of 2

Harness Required: MTWX02/2, CON2, DB1 Positive

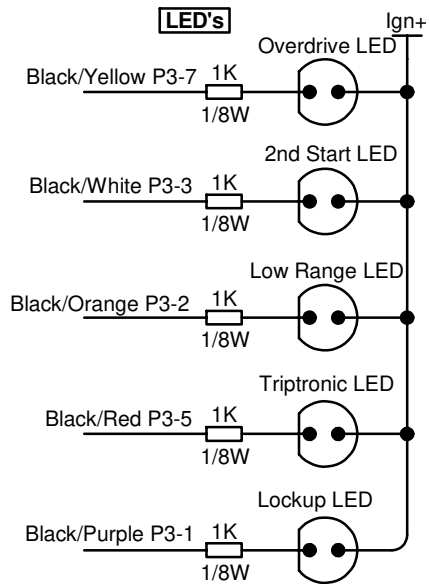

NB! Resistors are required LED's

Timing Retard Circuit

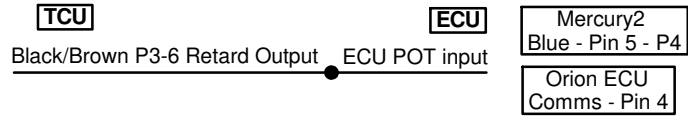

Tiptronic Buttons

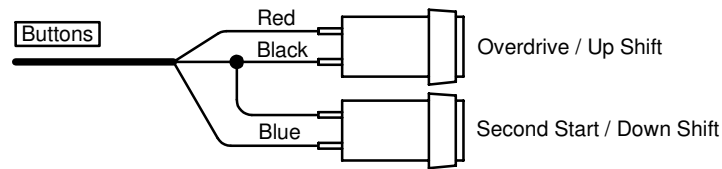

Reverse light Relay

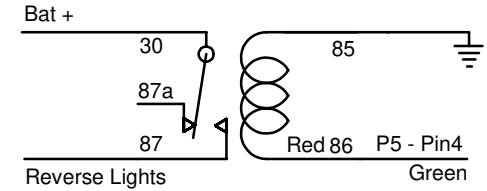

4 Map Switch

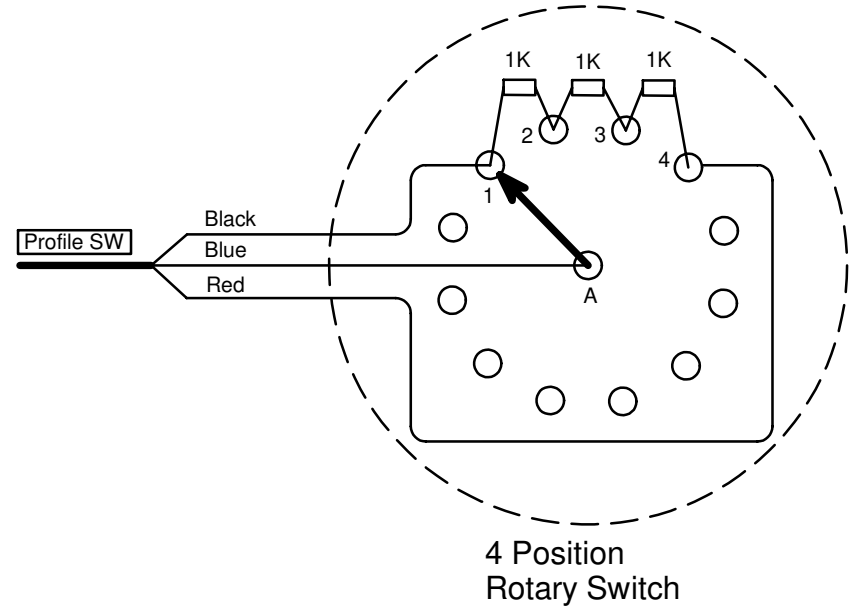

Aisin A343E 4Speed

Last Changed: 21/08/2019 Page 2 of 2

Harness Required: MTWX02/2, CON2, DB1 Positive

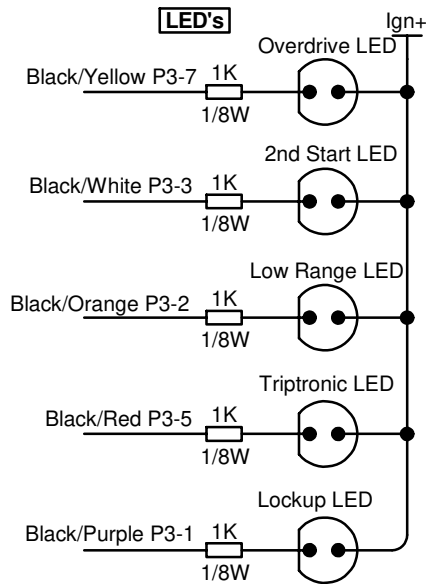

NB! Resistors are required LED's

Timing Retard Circuit

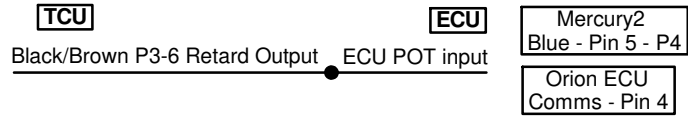

Tiptronic Buttons

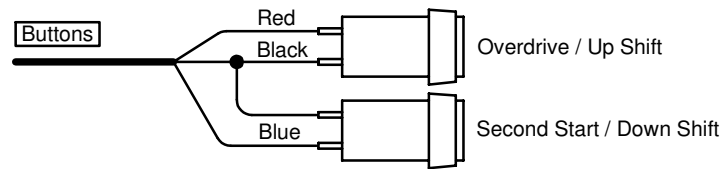

Reverse light Relay

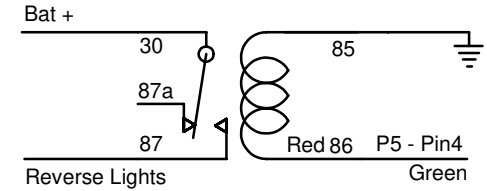

4 Map Switch

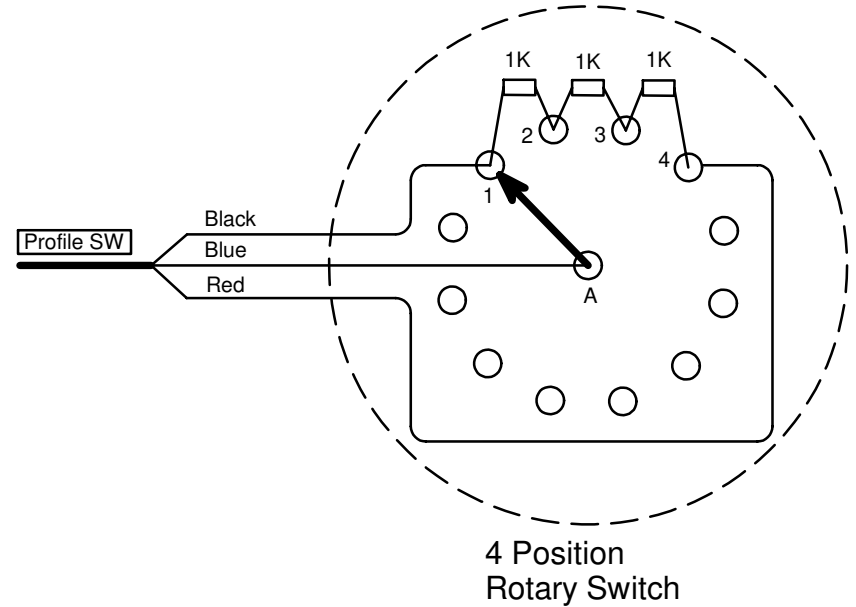

Aisin A343E 4Speed

Last Changed: 21/08/2019 Page 2 of 2

Harness Required: MTWX02/2, CON2, DB1 Positive

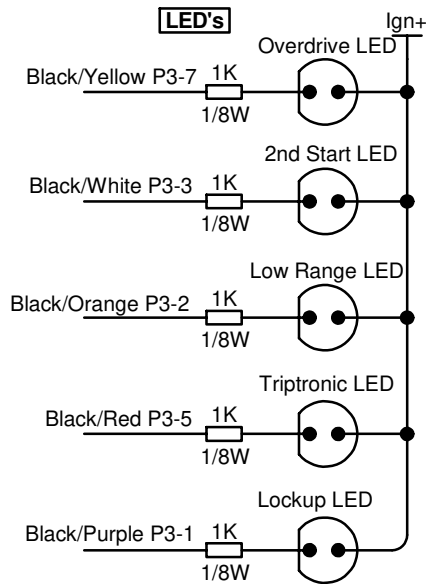

NB! Resistors are required LED's

Timing Retard Circuit

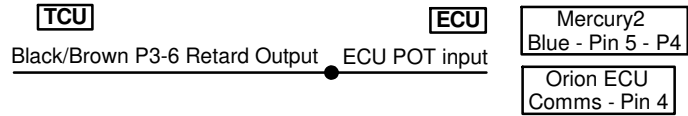

Tiptronic Buttons

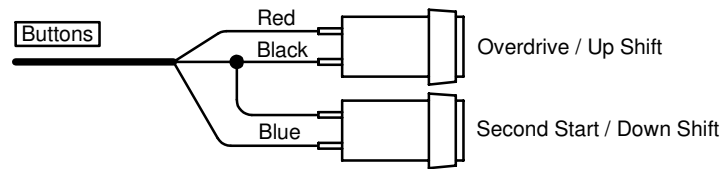

Reverse light Relay

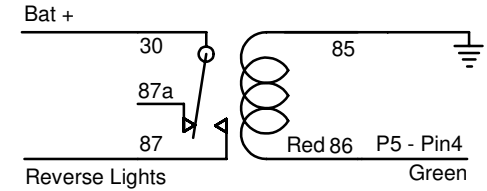

4 Map Switch

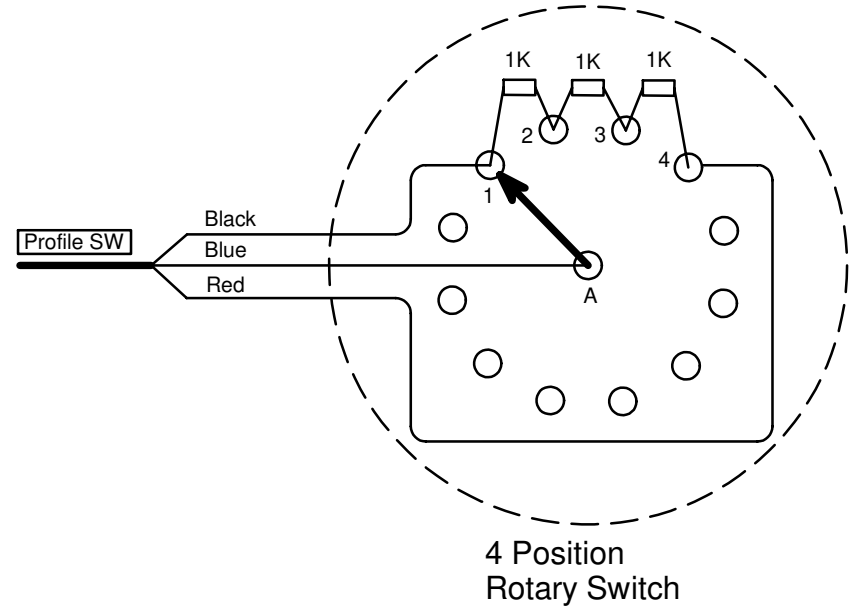

Aisin A343E 4Speed

Last Changed: 21/08/2019 Page 2 of 2

Harness Required: MTWX02/2, CON2, DB1 Positive

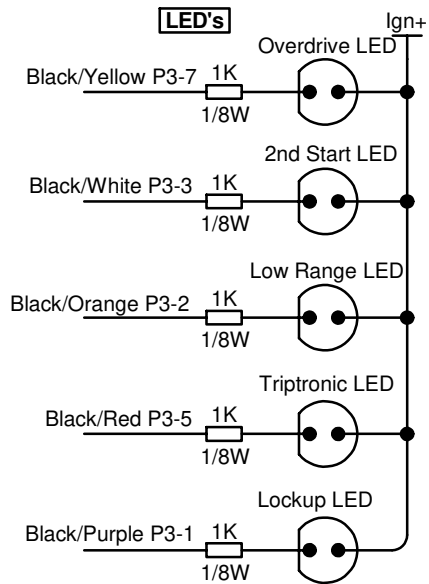

NB! Resistors are required LED's

Timing Retard Circuit

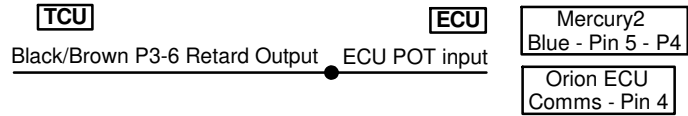

Tiptronic Buttons

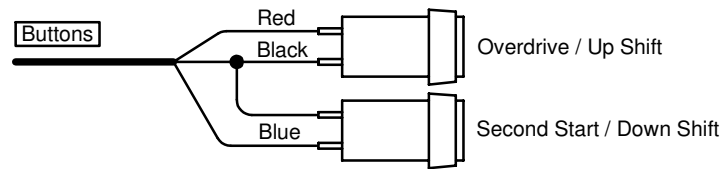

Reverse light Relay

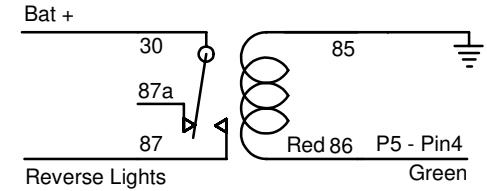

4 Map Switch

