

GM 4L60E 4Speed

Last Changed: 04/07/2018 Page 1 of 2
 Harness Required: MTWX01/2, MTDPX01/2, CON1

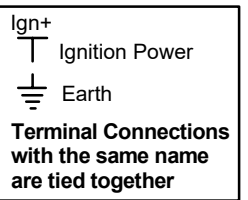
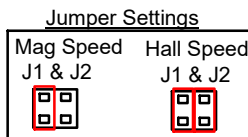
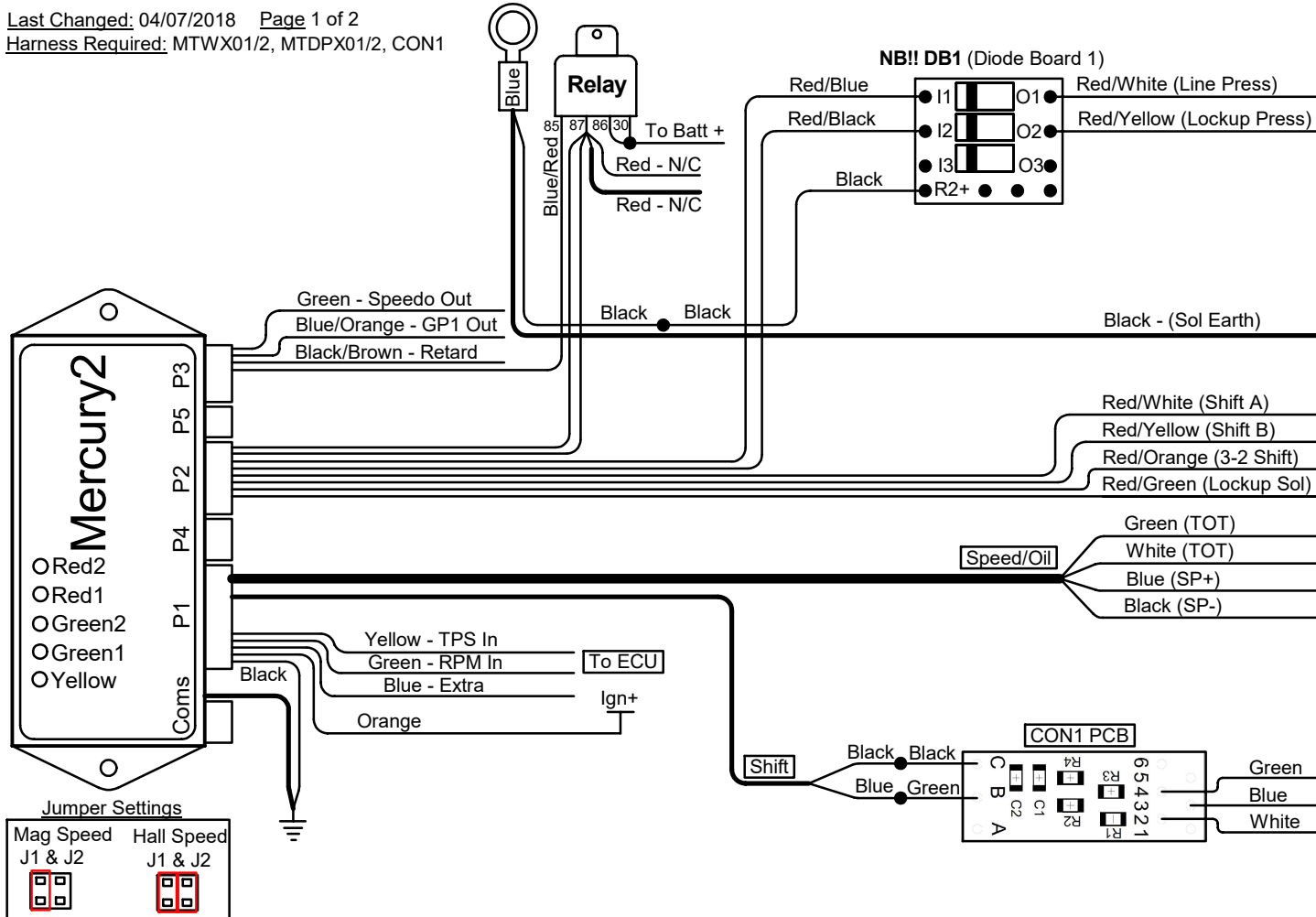

For Led's and Button's wiring go to Page 2

Transmission Connector

NB! Transmission Connector Pin View

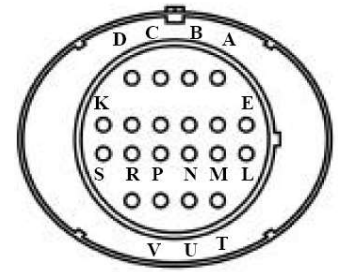

Pin	Harness	Spits Color	Connector	Resistance			
				Cold	Hot		
A	Gearbox	Red/White	Shift A	P2-1	20	40	Ω
B	Gearbox	Red/Yellow	Shift B	P2-6	20	40	Ω
D	Gearbox	Red/White	Line Pres	DB1 (P2-3)	3.5	4.6	Ω
C&E	Earth	Black					
K	Speed/Oil	Black	SP-	P1-11			
L	Speed/Oil	Green	TOT	P1-7			
M	Speed/Oil	White	TOT	P1-GND			
N	CON1 PCB	White	Switch A				
P	CON1 PCB	Blue	Switch C				
R	CON1 PCB	Green	Switch B				
S	Gearbox	Red/Orange	3-2 Shift	P2-2	9	14	Ω
T	Gearbox	Red/Green	Lockup Sol	P2-7	20	40	Ω
U	Gearbox	Red/Yellow	Lockup Pres	DB1(P2-8)	9	14	Ω
V	Speed/Oil	Blue	SP+	P1			

